

Town of Lynnville
Lynnville Town Council
January 21, 2025, Agenda

CALL MEETING TO ORDER

MOMENT OF SILENCE

PLEDGE OF ALLEGEANCE

ROLL CALL

APPROVAL OF MINUTES: April 2, 2024, and January 7, 2025

APPROVAL OF CURRENT BILLS: January 7, 2025 – January 21, 2025

Monthly Fund Activity: December 2024:

Revenue	\$10,593.88
Expenditures	\$18,791.99
Month End Balance	\$197,198.88

NEW BUSINESS:

1. Contractor's Application - Commonwealth
2. Lease Cancellation – Lot #89 – Barclay
3. Lease Transfer – Lot #89 – Sullivan
4. Bike race – 2025 Race
5. Approval to have Scouts use Community Center instead of Rec Building
6. Interest rates – LNB Community Bank – Misty
7. Discuss Indiana Bond Bank
8. Discussion of Road Conditions – Jeff
9. Charter ROW/ Permit Application
10. Discussion on sledding on Town properties
11. Community Center Coordinator
12. Park Superintendent
13. Event dates
 - a. Easter Egg Hunt
 - b. Breakfast with Easter Bunny
 - c. Town Wide Yard Sale
 - d. Halloween at the Park
14. Replace SCADA System – Jacob
15. Raise Utilities Rates
16. Discussion on Comprehensive Financial Plan
17. Discussion on Lynnville Town Priority List
18. Discussion on SBOA Invoice
19. Discussion on Reimbursement Policy
20. Discussion on Social Media Policy

Brian Cook, Town Manager

Work Report Submitted

PO Report Submitted

Work Order Report Submitted

Mike Mitchell, Town Marshal

Michael May, Fire Department

J. William Bruner, Attorney

Lauri Stockus, Clerk-Treasurer

Water Relocation Reimbursement from INDOT put in General account to be transferred to Utility account.

Upcoming:

1. Town Hall Closed – Presidents' Day

February 17

Doris Horn, Town Council Member/ Park Authority

Rachel Titzer, Town Council Member/ Park Authority

David Goldenberg, Town Council President /Park Authority

****ADDRESS THE FLOOR****

NEXT MEETING: February 4, 2025, 6:00pm Town Hall

TIME OF ADJOURNMENT

ANY AND ALL BUSINESS TO PROPERLY COME BEFORE THE LYNNVILLE TOWN COUNCIL

Persons with disabilities or non-English speaking persons who wish to attend a public meeting or hearing and need assistance should contact Lauri Stockus at 2025 Main St., Lynnville, TN 37619 or 812-922-5111 not later than one (1) week prior to any meeting or hearing. Every effort will be made to provide reasonable accommodation for any such person(s).

Lynnville Town Council January 21, 2025, Meeting Roll Call

Brian Cook, Town Manager

Present ___ Absent X

Mike Mitchell, Town Marshal

Present X Absent ___

Michael May, Fire Department

Present ___ Absent X

J. William Bruner, Attorney

Present X Absent ___

Lauri Stockus, Clerk-Treasurer

Present X Absent ___

David Goldenberg, Town Council Member/Park Authority

Present X Absent ___

Doris Horn, Town Council President/Park Authority

Present X Absent ___

Rachel Titzer, Town Council Member/Park Authority

Present X Absent ___

*Adam Oakley
for
Mike Mitchell*

Public Hearing Called to Order _____

Public Hearing Closed _____

Time Meeting Called to Order 6:00

Time Meeting Adjournment 7:32

January 21, 2025

1 John Schuler BLACK COAL

2 Adam Oakley Lynnville Police

3 KENNY MOORG BLACK COAL

4 Jeff Titco

5 Jay Silliker

6 Katie Hoffmann

7 Brandon Beck

8

9

10

11

12

13

14

15

16

17

18

19

20

21

22

23

24

25

Town of Lynnville

Town Council

January 21, 2025

Present: Adam Oakley, J. William Bruner, Lauri Stockus, Doris Horn, Rachel Titzer David Goldenberg

Absent: Brian Cook, Michael May

Call Meeting to Order at 6:00pm

Moment of Silence

Pledge of Allegiance

Roll Call

Approval of Minutes

Doris makes a motion to approve April 2, 2024, minutes as presented. Rachel seconds the motion. Rachel in favor. Doris in favor. David in favor. Motion carries.

January 7, 2025 – Tabled

Approval of Current Bills

Rachel makes a motion to approve the current bills of January 7, 2025 – January 21, 2025, as presented. Doris seconds the motion. Rachel in favor. Doris in favor. David in favor. Motion carries

Monthly Fund Activity: December 2024:

Revenue	\$10,593.88
Expenditure	\$18,791.99
Month End Balance	\$197,198.88

New Business:

Contractor's Application - Commonwealth

Contractor's Application #3 for \$45,447.75 to Guardian will close the Water Relocation Project.

Doris makes a motion to approve Contractor's Application #3 for \$45,447.75. Rachel seconds the motion. Rachel in favor. Doris in favor. David in favor. Motion carries.

SRF Preliminary Engineering Report and SRF Asset Management Plan were presented for Town Council Review. With complete analysis of the full system there may be potential for funding for the utility systems.

Lease Cancellation – Lot #89 – Barclay

Rachel makes a motion to approve the Lease Cancellation for Lot #89. Doris seconds the motion. Rachel in favor. Doris in favor. David in favor. Motion carries

Lease Transfer – Lot #89 – Sullivan

Rachel makes a motion to approve the Lease Transfer for Lot #89. Doris seconds the motion. Rachel in favor. Doris in favor. David in favor. Motion carries

Bike race – 2025 Race

Doris makes a motion to approve usage of camping, Recreational Building, and Shelter House usage for April 26 – April 27, 2025, for annual race. David seconds the motion. Rachel in favor. Doris in favor. David in favor. Motion carries

Approval to have Scouts use Community Center instead of Rec Building

The Scouts have outgrown the Recreational Building for their meetings. They have combined Eiberfeld and Lynnville which took them from 6 scouts to 26 scouts. Doris makes a motion to approve the Scouts transferring the meetings from the Recreational Building to the Community Center on 1st and 3rd Thursdays. Rachel seconds the motion. Rachel in favor. Doris in favor. David in favor. Motion carries

Interest rates – LNB Community Bank – Misty

Submitted current interest rates.

Discuss Indiana Bond Bank

Tabled

Discussion of Road Conditions – Jeff

Last time Terry Ln was paved he told Council members there were setting spots and crack down the street above sewer line. It would need to be looked at more closely and not just paved over. He was then told it would be fine and there would not be a problem. Less than a year after it was paved it started sinking in the same spot and there is a significant crack down the middle of the road. This needs to be addressed and fixed correctly this time. David stated this issue was being addressed with Metzger Construction currently.

Charter ROW Permit Application

Tabled – No representation present and the Council would like Brian to look at the information.

Discussion on sledding on Town properties

Rachel contacted insurance agent to get their view on the subject. The insurance agent stated they do not view it any differently than playground equipment so there is no issue with them. All 3 Council members agree there will be no formal restrictions placed on sledding on Town properties.

Community Center Coordinator

Rachel makes a motion to approve the Community Center Coordinator position created. Doris seconds the motion. Rachel in favor. Doris in favor. David in favor. Motion carries

Doris makes a motion to approve Kaila Byers to be the Community Center Coordinator. Rachel seconds the motion. Rachel in favor. Doris in favor. David in favor. Motion carries

Park Superintendent

Doris makes a motion to approve Kathleen Hofmann to be the Park Superintendent. Rachel seconds the motion. Rachel in favor. Doris in favor. David in favor. Motion carries

Event dates

Easter Egg Hunt	04/12/2025	Holiday Parade	11/30/2025
Breakfast with Easter Bunny	04/19/2025	Tree Lighting	12/06/2025
Town Wide Yard Sale	04/26/2025	Breakfast with the Grinch	12/13/2025
Halloween at the Park	10/18/2025		

New Events Rachel would like to add this year:

Mother’s Day Tea	05/03/2025
4 th of July Event	07/04/2025

More on these new events as the plans get worked out.

Replace SCADA System – Jacob

Included in the above SRF Asset Management Plan presented above.

Raise Utilities Rates

Tabled – Talking with Chris and Baker Tilly tomorrow about Rate Study.

Discussion on Comprehensive Financial Plan

Will be discussing with Paige from Baker Tilly.

Discussion on Lynnville Town Priority List

Nothing new to add

Discussion on SBOA Invoice

David spoke with SBOA. There is no reduction or discount on pricing. Rates are set. Line item in budget will be set up to be put aside for next audit.

Discussion on Reimbursement Policy

Doris makes a motion to approve the Reimbursement Policy as presented. Rachel seconds the motion. Rachel in favor. Doris in favor. David in favor. Motion carries

Discussion on Social Media Policy

Mr. Bruner will review the policy.

Brian Cook, Town Manager – Not Present

Work Report Submitted

P.O. Report Submitted

Work Order Report Submitted

Mike Mitchell, Town Marshal

Adam Oakley present for Mike Mitchell

Nothing to Add

Michael May, Fire Department – Not Present

J. William Bruner, Town Attorney

Verified full judgement has been received from Wheaton case. Court case for tax sale for Violet Ln leased property is 02/13/2025 and David will be attending to represent the Town of Lynnville.

Redistricting the Town of Lynnville for voting districts should start working now. It needs to be completed and sent to the county by June 30, 2025.

Lauri Stockus, Clerk-Treasurer

Water Relocation Reimbursement from INDOT put in General account to be transferred to Utility account. The paperwork was sent to INDOT 12/30/2024, they received it 01/02/2025 and payment went into account 01/29/2025.

Upcoming:

1. Town Hall Closed – Presidents' Day

February 17

Rachel Titzer, Council Member / Park Authority

Nothing to add.

Doris Horn, Council Member / Park Authority

Nothing to add.

David Goldenberg, Council President / Park Authority

Billing for ViV the old website company needs to be straightened out. The new website company is VisualRush. Rachel said she was waiting on all the statements and would talk to Lauri about it.

Concerning the Community Crossing Grant application, according to Clint Lamb, the highest possible amount should be requested. There was some discussion on the matching funds coming out of the bond. Rachel stated this was a decision for the Redevelopment Committee and not the Town Council.

David is going to set up a Redevelopment Committee meeting as soon as possible to discuss the matching funds for CCMG application and \$150,000 estimate from Duke for trail lighting.

Next Meeting: February 4, 2025, 6:00pm @ Town Hall

Doris makes the motion to adjourn the Town Council meeting. Rachel seconds the motion. Rachel in favor. Doris in favor David in favor. The meeting is adjourned at 7:32pm.

Lynnville Town Council:

Rachel Titzer, Council Member / Park Authority

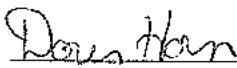

Doris Horn, Council Member / Park Authority

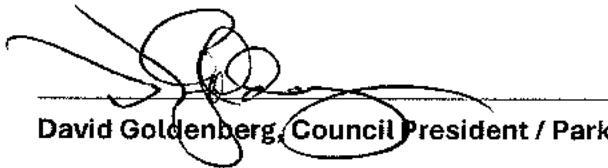

David Goldenberg, Council President / Park Authority

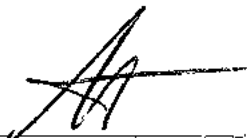
Attest: 

Lauri Stockus, Clerk-Treasurer

Persons with disabilities or non-English speaking persons who wish to attend a public meeting or hearing and need assistance should contact Lauri Stockus, at Town Hall, 207 Main St., Lynnville, IN 47619 or 812-922-5111 not later than one (1) week prior to any meeting or hearing. Every effort will be made to provide reasonable accommodation for any such person or person.

ACCOUNTS PAYABLE VOUCHER REGISTER SUMMARY

TOWN OF LYNNVILLE

GOVERNMENTAL UNIT

AGENCY

APV Register Batch - January 21, 2025 Town Council Meeting

Page 1 of 2 Pages

Issued by the TOWN OF LYNNVILLE-2018

General Form No. 364 (1997) APVREGISTER_SUM.FR3

NOTES: (1) Use both sides of the form if needed. Signatures of governing board should appear only on the final page of each meeting in which accounts payable vouchers are allowed.
 (2) The Memorandum is for entering action on accounts payable vouchers if disallowed in whole or in part, if continue to a later meeting of governing board, or for other pertinent information.

Check Date	Vendor	Name of Claimant	Office Department	Amount of Voucher	Amount Allowed	Warrant	Check/ Memorandum (See Note (2) Above)
//	1202	LYNNVILLE VOL FIRE DEPT	OPERATING SUPPLIES	310.11			January 25 Snow Storm
//	241	SAM'S CLUB MC/SYNCO	TRANSPORTATION	280.00			Alliance Spring Conference Room - French
//	1202	LYNNVILLE VOL FIRE DEPT	OPERATING SUPPLIES	47.96			January 25 Snow Storm
//	241	SAM'S CLUB MC/SYNCO	TRANSPORTATION	265.00			Alliance Spring Conference Registration -
//	1202	LYNNVILLE VOL FIRE DEPT	OPERATING SUPPLIES	25.99			January 25 Snow Storm
//	241	SAM'S CLUB MC/SYNCO	0 -LRS-STREET REPAIR	491.37			January 2025 Storm - Rock Salt
//	171	HD SUPPLY FACILITIES	MATERIALS AND	97.68			Ammonia Tests
//	5	IDEM	PROFESSIONAL SERVICES	456.00			PWS Fee - SVC: 480
//	6	INDIANA UNDERGROUND	PROFESSIONAL SERVICES	89.77			4th Quarter tickets
//	1202	LYNNVILLE VOL FIRE DEPT	OPERATING SUPPLIES	142.75			January 25 Snow Storm
//	241	SAM'S CLUB MC/SYNCO	0 -TOWN MARSHAL -	56.51			Monthly service - Microsoft (3)
//	70	TREASURER OF STATE	WATP DEPRECIATING	13648.80			2020/2021/2022/2023 Audit
//	102	4JS HARDWARE LLC	9 -BUILDING REPAIR /	61.26			Supplies for Rec Building Repair
//	54	AUTOZONE STORES LLC	9 -EQUIPMENT REPAIR /	6.07			Taillight for Ranger
//	171	HD SUPPLY FACILITIES	CHEMICALS	97.67			TNT 832
//	22	HOPF EQUIPMENT INC	9 -EQUIPMENT REPAIR /	6598.53			Kubota Repair
//	5	IDEM	PROFESSIONAL SERVICES	1215.00			Base fee, Flow fee
//	6	INDIANA UNDERGROUND	PROFESSIONAL SERVICES	89.78			4th Quarter tickets
//	1202	LYNNVILLE VOL FIRE DEPT	OPERATING SUPPLIES	229.75			January 25 Snow Storm
//	151	NICHOLS FIRE & FLEET INC.	EQUIPMENT / MACHINERY	113.20			Radio Batteries
//	241	SAM'S CLUB MC/SYNCO	MATERIALS AND	54.02			Monthly service - Microsoft (5)
//	116	SIEGEL'S CORPORATION	BUNKER GEAR	119.99			Tailgrip Tac Sidzip
//	70	TREASURER OF STATE	WTP DEPRECIATING FUND	13648.80			2020/2021/2022/2023 Audit
//	267	WILCOX EARTHWORKS, INC	PROFESSIONAL SERVICES	994.50			12222 Petersburg Rd - Added to PO 2570
01/08/2025	28	EMERGENCY SERVICES	MAINTENANCE	305.00	305.00	2144	Annual service
01/21/2025	99999	AMERICAN LEGION POST 44	OPERATING SUPPLIES	432.00	432.00	2145	Flags
01/14/2025	274	KATHERINE HOFMANN	9 -BUILDING REPAIR /	142.30	142.30	2371	Reimburse - Supplies for repairs at Rec
01/09/2025	99999	BRENDA DONOHOO	5 -DEPOSIT REFUND	150.00	150.00	2497	Community Center rental deposit Refund
01/21/2025	275	BILL TAYLOR	5 -REPAIRS AND	4040.00	4040.00	2498	Update bathrooms - 1/2 to begin job
01/14/2025	189	QUADIENT, INC. POSTAGE	MATERIALS AND	196.56	196.56	6051	Monthly service
01/21/2025	66	CORE & MAIN LP	MATERIALS AND	44.77	44.77	6052	Brass S190
02/20/2024	199	FORCE SCIENCE, LTD.	0 -TOWN MARSHAL -	395.00	395.00	7231	Realistic De-Escalation- Training
01/08/2025	273	INDIANA ASSOCIATION OF	0 -TOWN MARSHAL -	235.00	235.00	7448	Annual membership
01/21/2025	249	KARLA KOLLEY	0 -CLEANING REPAIRS /	100.00	100.00	7449	Monthly service
01/21/2025	178	OSADIAH J. GEORGES	0-PUBLIC IMPROVEMENT	1457.57	1457.57	7450	Replace back door of Annex
01/08/2025	905	IND DEPT OF WORKFORCE	PAYROLL NET SALARIES	120.58	120.58	23470	4th Quarter Balance Due
01/08/2025	235	BFI WASTE SERVICES OF	SLUDGE REMOVAL	4865.17	4865.17	23471	Monthly service
01/10/2025	1602	PAYROLL	0-COUNCIL MEMBERS	3147.27	3147.27	23473	Gen Council
01/10/2025	1602	PAYROLL	SALARIES/WAGES	8121.93	8121.93	23474	WTP Wages
01/10/2025	1602	PAYROLL	PAYROLL FEDERAL 941	11018.56	11018.56	23475	Net DD Entry

ACCOUNTS PAYABLE VOUCHER REGISTER SUMMARY

TOWN OF LYNNVILLE

GOVERNMENTAL UNIT

AGENCY

NOTES: (1) Use both sides of the form if needed. Signatures of governing board should appear only on the final page of each meeting in which accounts payable vouchers are allowed.
 (2) The Memorandum is for entering action on accounts payable vouchers if disallowed in whole or in part, if continue to a later meeting of governing board, or for other pertinent information.

Page 2 of 2 Pages

As Issued by the TOWN OF LYNNVILLE-2018

General Form No. 364 (1997) APVREGISTER_SUM.FRX

Check Date	Vendor	Name of Claimant	Office Department	Amount of Voucher	Amount Allowed	Warrant	Check/Memorandum (See Note (2) Above)
01/10/2025	1009	PAYROLL	8-REPAIRS AND	89.82	89.82	23476	Community Center-Repairs/Maint
01/10/2025	1009	PAYROLL	6-GROUNDSKEEPER	3149.65	3149.65	23477	Park Groundskeeper
01/14/2025	31	DUKE ENERGY	9-ELECTRIC	278.04	278.04	23478	Monthly service - TH
01/14/2025	31	DUKE ENERGY	9-ELECTRIC	1015.45	1015.45	23479	Monthly service
01/14/2025	31	DUKE ENERGY	PURCHASED POWER	351.16	351.16	23480	Monthly service
01/14/2025	84	FEDERAL REVENUE SERVICE	PAYROLL FEDERAL 941	2674.09	2674.09	23481	W/H
01/14/2025	1200	LYNNVILLE UTILITIES	7-WATER/SEWER	93.58	93.58	23482	Monthly service
01/14/2025	1200	LYNNVILLE UTILITIES	7-WATER/SEWER	93.58	93.58	23483	Monthly service
01/14/2025	276	OTW/B/300	7-MATERIALS AND	210.95	210.95	23497	Pump battery/flashlights
				83672.54	42728.03		

Payfile Distribution Journal

For payfile ending 01/10/2025 12:00:00 AM

All Records

Distribution Name	Account Number	Wage Amount	Deduction Name	Deduction Amount
Location: Groundskeeping				
Gen Groundskeeping	1101001114.000	\$452.09	Federal Withholding	\$436.09
MVH Wages	2201001112.000	\$690.08	FICA Withholding	\$372.94
Community Center-Rep	2226000361.000	\$83.53	Medicare Withholding	\$87.22
Town Manager	4437020111.400	\$182.11	State Withholding	\$180.45
WTP Wages	6101001112.000	\$1315.08	Local Withholding	\$30.08
WWTP Wages	6201001112.000	\$3471.97	Ambetter from MHS- P	\$132.12
			DD - Centurion Feder	\$516.09
			DD - German American	\$3489.67
			DD - IN Members Cred	\$824.85
			DD - Old National	\$77.66
			Delta Dental	\$7.82
			Globe Life	\$25.56
			VSP Vision Care	\$14.31
Groundskeeping Wages Total		\$6194.86	Deductions Total	\$6194.86
			Net Pay	\$0.00
Location: Park				
Park Groundskeeper	2204001111.000	\$1483.16	Federal Withholding	\$0.00
Park Employees	2204001113.000	\$1063.09	FICA Withholding	\$155.66
			Medicare Withholding	\$36.39
			State Withholding	\$75.31
			Local Withholding	\$12.54
			DD - Diamond Valley	\$595.23
			DD - Fifth Third Ban	\$43.34
			DD - LNB Community	\$573.44
			DD - Peoples	\$1018.58
			Globe Life	\$35.76
Park Wages Total		\$2546.25	Deductions Total	\$2546.25
			Net Pay	\$0.00
Location: Town Hall				
Gen Council	1101001111.000	\$271.29	Federal Withholding	\$220.80
Gen Town Hall	1101001111.240	\$114.87	FICA Withholding	\$288.85
Gen Clerk Treasurer	1101001112.000	\$566.43	Medicare Withholding	\$67.54
Park Clerk Treasurer	2204001112.000	\$89.40	State Withholding	\$139.76
Park Extra Help	2204001114.000	\$63.83	Local Withholding	\$32.24
Park Board Members	2204001115.000	\$229.56	AFLAC- Post Tax	\$29.95
Town Marshal	2240200111.400	\$651.00	AFLAC- PreTax	\$26.16
WTP Wages	6101001112.000	\$1386.29	DD - Bancorp	\$1050.45
WWTP Wages	6201001112.000	\$1386.29	DD - Fifth Third Ban	\$309.05
			DD - LNB Community	\$1725.93
			DD - Liberty Federal	\$255.86

Payfile Distribution Journal

For payfile ending 01/10/2025 12:00:00 AM

All Records

Distribution Name	Account Number	Wage Amount	Deduction Name	Deduction Amount
			DD - USAA Federal Sa	\$538.41
			Globe Life	\$73.96
	Town Hall Wages Total	\$4758.96	Deductions Total	\$4758.96
			Net Pay	\$0.00

Location: GRAND TOTAL

Gen Council	1101001111.000	\$271.29	Federal Withholding	\$656.89
Gen Town Hall	1101001111.240	\$114.87	FICA Withholding	\$817.45
Gen Clerk Treasurer	1101001112.000	\$566.43	Medicare Withholding	\$191.15
Gen Groundskeeping	1101001114.000	\$452.09	State Withholding	\$395.52
MVH Wages	2201001112.000	\$690.08	Local Withholding	\$74.86
Park Groundskeeper	2204001111.000	\$1483.16	AFLAC- Post Tax	\$29.95
Park Clerk Treasurer	2204001112.000	\$89.40	AFLAC- PreTax	\$26.16
Park Employees	2204001113.000	\$1063.09	Ambetter from MHS- P	\$132.12
Park Extra Help	2204001114.000	\$63.83	DD - Bancorp	\$1050.45
Park Board Members	2204001115.000	\$229.56	DD - Centurion Feder	\$516.09
Community Center-Rep	2226000361.000	\$83.53	DD - Diamond Valley	\$595.23
Town Marshal	2240200111.400	\$651.00	DD - Fifth Third Ban	\$352.39
Town Manager	4437020111.400	\$182.11	DD - German American	\$3489.67
WTP Wages	6101001112.000	\$2701.37	DD - IN Members Cred	\$824.85
WWTP Wages	6201001112.000	\$4858.26	DD - LNB Community	\$2299.37
			DD - Liberty Federal	\$255.86
			DD - Old National	\$77.66
			DD - Peoples	\$1018.58
			DD - USAA Federal Sa	\$538.41
			Delta Dental	\$7.82
			Globe Life	\$135.28
			VSP Vision Care	\$14.31
	GRAND TOTAL Wages Total	\$13500.07	Deductions Total	\$13500.07
			Net Pay	\$0.00

Hours Report Summary

For payroll ending 01/10/2025 12:00:00 AM
All Records

Paytype : Normal

Distribution Name	Account Number	Units Taken	PTO	Hours Worked	Salary Hours	Amount
Gen Council	1101001111.000	0.00000		0.00000	0.00000	\$271.29
Gen Town Hall	1101001111.240	0.00000		4.99500	0.00000	\$114.87
Gen Clerk Treasurer	1101001112.000	0.00000		0.00000	0.00000	\$566.43
Gen Groundskeeping	1101001114.000	0.00000		19.26500	0.00000	\$452.09
MVH Wages	2201001112.000	0.00000		26.64400	0.00000	\$690.08
Park Groundskeeper	2204001111.000	0.00000		103.50000	0.00000	\$1483.16
Park Clerk Treasurer	2204001112.000	0.00000		0.00000	0.00000	\$89.40
Park Employees	2204001113.000	0.00000		79.50000	0.00000	\$1063.09
Park Extra Help	2204001114.000	0.00000		2.77500	0.00000	\$63.83
Park Board Members	2204001115.000	0.00000		0.00000	0.00000	\$229.56
Community Center-Repairs/Maint	2226000361.000	0.00000		3.83100	0.00000	\$83.53
Town Marshal	2240200111.400	0.00000		23.25000	0.00000	\$651.00
Town Manager	4437020111.400	0.00000		4.80000	0.00000	\$182.11
WTP Wages	6101001112.000	0.00000		66.10500	0.00000	\$2701.37
WWTP Wages	6201001112.000	0.00000		99.70500	0.00000	\$3976.15
Subtotals for Paytype : Normal		0.00000		434.37000	0.00000	\$12617.96

Paytype : Overtime

Distribution Name	Account Number	Units Taken	PTO	Hours Worked	Salary Hours	Amount
MVH Wages	2201001112.000	0.00000		0.00000	0.00000	\$0.00
Community Center-Repairs/Maint	2226000361.000	0.00000		0.00000	0.00000	\$0.00
WTP Wages	6101001112.000	0.00000		0.00000	0.00000	\$0.00
WWTP Wages	6201001112.000	0.00000		15.50000	0.00000	\$882.11
Subtotals for Paytype : Overtime		0.00000		15.50000	0.00000	\$882.11

Paytype : PTO

Distribution Name	Account Number	Units Taken	PTO	Hours Worked	Salary Hours	Amount

Installed by the TOWN OF LYNNVILLE-2018

Fund Report

Date: 01/21/2025 12:25:58
FUNDACCOUNTS.FRX

Selected Funds

From 12/01/2024 Thru 12/31/2024

Ordered By Bank Number, Fund Number

FUND TITLE	BALANCE OF YEAR	REVENUE YTD	DISBURSED YTD	BALANCE BEOB OF MONTH	REVENUE MTD	DISBURSED MTD	CURRENT BALANCE
**Bank Number 9							
0001 LYNNVILLE PARK	173936.88	287927.99	264170.99	205396.88	10593.88	18791.99	197198.88
Subtotal Bank Number 9	173936.88	287927.99	264170.99	205396.88	10593.88	18791.99	197198.88
TOTAL GRAND TOTAL	173936.88	287927.99	264170.99	205396.88	10593.88	18791.99	197198.88

Lauri Stockus

From: Aaron Rohner, PE (IN, KY) <arohner@contactcei.com>
Sent: Thursday, January 23, 2025 3:11 PM
To: Rachel Titzer; David Goldenberg; Doris Horn
Cc: Lauri Stockus
Subject: [External]Town of Lynnville Meeting Items
Attachments: Lynnville - PAY APP #3.pdf; 2025-01 PER - AMP.pdf

Good afternoon, Board.

I wanted to follow up on a few items:

1. **Town of Lynnville Wastewater Preliminary Engineering Report (PER) and Asset Management Plan (AMP) Contract**

Following our discussion on Friday January 17th, Commonwealth Engineers have drafted a Contract for Council's approval to complete the PER and AMP.

By authorizing this Contract, Commonwealth Engineers will compile a PER in accordance with Indiana Finance Authority (IFA) State Revolving Fund (SRF). This PER will be submitted to IFA for funding considering on April 1st, 2025. This PER will include a summary and analysis of the existing wastewater system (Wastewater Treatment Plant, Lift Stations, and Collection System), development of proposed projects and why they are needed, financial analysis for each project, and a recommended project.

As part of the IFA SRF funding process, an asset management plan will be completed. This plan consists of three (3) parts, Technical, Managerial, and Financial. Commonwealth Engineers will be completing the Technical and Managerial Section of the plan. This includes summary of the entire wastewater system, age of the existing infrastructure, standard operating procedures for daily operation, and daily clerical process for the utility.

Attached is the contract for review and approval by Council at the next meeting. I will plan on attending the meeting to present the Contract and answer any questions Council may have. Beforehand, if Council has any questions, please feel free to reach out.

2. **SR 61 Waterline Relocation Project**

Attached is the copy of the pay application presented and approved at the last meeting. This payment application is for FINAL PAYMENT to Guardian. This does NOT free them up from performing warranty work on the project.

This payment will go through the INDOT reimbursement process.

3. **217 Oak Street Drainage**

During our meeting on last week, a drainage issue was discussed along Oak Street (near 217 Oak Street). Following the conversation, it was mentioned that the Town would like Commonwealth to assist with analyzing the issue.

Scope of Service – Commonwealth Engineers will review the area for watershed concerns along the immediate area of 217 Oak Street. Following the review, a brief technical memo will be developed to summarize the findings and present it to the board. Work will include a site visit to review with the Town, pictures of the area, brief sketches demonstrating the area of concern, and potential remediation of the issue.

Contractor's Application for Payment

Owner: Town of Lynnville
 Engineer: Commonwealth Engineers, Inc.
 Contractor: _____
 Project: S.R. 61 Water Line Relocation
 Contract: S.R. 61 Water Line Relocation

Owner's Project No.: _____
 Engineer's Project No.: W23068
 Contractor's Project No.: _____

Application No.: 3 Application Date: 1/17/2025
 Application Period: From 10/01/2024 to 1/31/2025

1. Original Contract Price	
2. Net change by Change Orders	\$ 255,430 - 00
3. Current Contract Price (Line 1 + Line 2)	\$ 00 - 00
4. Total Work completed and materials stored to date (Sum of Column G Lump Sum Total and Column J Unit Price Total)	\$ 255,430 - 00
5. Retainage	\$ 255,430 - 00
a. <u>5%</u> X \$ 255,430 - Work Completed	\$
b. <u>5%</u> X \$ - Stored Materials	\$
c. Total Retainage (Line 5.a + Line 5.b)	\$ -
6. Amount eligible to date (Line 4 - Line 5.c)	\$
7. Less previous payments (Line 6 from prior application)	\$ 255,430 - 00
8. Amount due this application	\$210,002 .25
9. Balance to finish, including retainage (Line 3 - Line 4)	\$ 45,427 .75
	\$ 00.00

PROJECT ENGINEER

Contractor's Certification

The undersigned Contractor certifies, to the best of its knowledge, the following:
 (1) All previous progress payments received from Owner on account of Work done under the Contract have been applied on account to discharge Contractor's legitimate obligations incurred in connection with the Work covered by prior Applications for Payment; (2) Title to all Work, materials and equipment incorporated in said Work, or otherwise listed in or covered by this Application for Payment, will pass to Owner at time of payment free and clear of all liens, security interests, and encumbrances (except such as are covered by a bond acceptable to Owner indemnifying Owner against any such liens, security interest, or encumbrances); and (3) All the Work covered by this Application for Payment is in accordance with the Contract Documents and is not defective; (4) all items and amounts on the face of this Contractor's Application for Payment are correct; (5) all Work has been performed and/or material supplied in full accordance with the requirements of the referenced Contract, and/or duly authorized deviations, substitutions, alterations, and/or additions; (6) the foregoing is a true and correct statement of the Contract account up to and including the last day of the period covered by this Periodic Estimate; (7) no part of the "Balance Due This Payment" has been received, and (8) the undersigned and his subcontractors have - (check applicable line):
 a. Complied with all labor provisions of said Contract.
 b. Complied with all labor provisions of said Contract except in those instances where an honest dispute exists with respect to said labor provisions (if (b) is checked, describe briefly nature of dispute on an attached sheet).

Contractor: Guardian Private Utility Locating
 Signature: Tammy Lemmer Date: 1/17/2025

Recommended by Engineer
 By: [Signature]
 Title: PROJECT ENGINEER
 Date: 1/20/2025

Approved by Owner
 By: [Signature]
 Title: Council President
 Date: 1/21/2025

Approved by Funding Agency
 By: _____
 Title: _____
 Date: _____

By: _____
 Title: _____
 Date: _____

Progress Estimate - Unit Price Work

Owner: Town of Lymville
 Engineer: Commonweath Engineers, Inc.
 Project: S.R. 61 Water Line Relocation
 Contract: S.R. 61 Water Line Relocation

Contractor's Application for Payment
 Owner's Project No.: W23068
 Engineer's Project No.:
 Contractor's Project No.:

Application No.: 3 Application Period: From 10/01/2024 to 1/31/2025 Application Date: 1/17/2025

Bid Item No.	Description	Contract Information			F	G	H	I	J	K	L
		C	D	E							
1a	Mobilization / Demobilization	1	L Sum	7,500.00	Original Contract						
1b	Construction Engineering	1	L Sum	7,500.00	7,500.00	375.00		7,500.00	100%		
2a	6" PVC C-900 Pipe, DR 18	837	LF	60.00	50,220.00	3,750.00		7,500.00	100%		
2b	6" PVC C-900, DR 18, Restrained Joint	291	LF	60.00	17,460.00			50,220.00	100%		
2c	14" PVC C-900 Pipe, DR 18, Restrained Joint Casing Pipe	60	LF	242.00	14,520.00			17,460.00	100%		
2d	Existing Water Main Abandonment	1	L Sum	10,000.00	10,000.00	10,000.00		10,000.00	100%		
3a	6" Gate Valve and Valve Box	6	Each	3,500.00	21,000.00			10,000.00	100%		
3b	6" Line Stops	2	Each	6,500.00	13,000.00			13,000.00	100%		
4	Connection to Existing 6" Main	6	Each	5,000.00	30,000.00			30,000.00	100%		
5a	Fire Hydrant Assembly w/Hydrant Valve	4	Each	7,000.00	28,000.00			28,000.00	100%		
5b	Air Relief Valve Assembly	2	Each	10,000.00	20,000.00			20,000.00	100%		
6	Pressure Testing and Disinfection	1	L Sum	5,000.00	5,000.00	500.00		5,000.00	100%		
7a	3/4"-1" Water Service Reconnection, Long Service	6	Each	1,250.00	7,500.00			4,500.00	100%		
7b	3/4"-1" Water Service Reconnection, Short Service	1	Each	1,250.00	1,250.00			7,500.00	100%		
8a	Remove Existing Hydrant	2	Each	750.00	1,500.00			1,250.00	100%		
8b	Remove Existing Valve and Box	3	Each	500.00	1,500.00			1,500.00	100%		
9	Granular Backfill	439	LF	0.00	0.00			1,500.00	100%		
10	Compacted Aggregate, No. 53	439	LF	0.00	0.00			1,500.00	100%		
11a	Asphalt Pavement Restoration, Trench Width	439	LF	0.00	0.00			1,500.00	100%		
11b	INDOT Right-of-Way Restoration	1	L Sum	1,000.00	1,000.00	1,000.00		1,000.00	100%		
					Original Contract Totals	\$	\$	\$	\$	100%	\$

Progress Estimate - Unit Price Work

Owner: Town of Lynnville
Engineer: Commonwealth Engineers, Inc.
Contractor: S.R. 61 Water Line Relocation
Project: S.R. 61 Water Line Relocation
Contract: S.R. 61 Water Line Relocation

Owner's Project No.: W23068
Engineer's Project No.:
Contractor's Project No.:

Application No.: 3
Application Period: From 10/01/2024 to 1/31/2025
Application Date: 1/17/2025

Contractor's Application for Payment

A Bid Item No.	B Description	C Item Quantity			D Contract Information			E Unit Price (\$)			F Value of Bid Item (C X E) (\$)			G Work Completed			H Value of Work Completed to Date (E X G) (\$)	I Materials Currently Stored (not in G) (\$)	J Work Completed and Materials Stored to Date (H + I) (\$)	K % of Value of Item (J / F) (%)	L Balance to Finish (F - J) (\$)		
		1	2	3	4	5	6	7	8	9	10	11	12	13	14								
12	Temporary Erosion and Sediment Control	1	L Sum		2,500.00		2,500.00		2,500.00		2,500.00		2,500.00		2,500.00		2,500.00		100%				
13	Maintenance of Traffic	1	L Sum		2,500.00		2,500.00		2,500.00		2,500.00		2,500.00		2,500.00		2,500.00		100%				
14	Final Grading and Seeding	1	L Sum		3,500.00		3,500.00		3,500.00		3,500.00		3,500.00		3,500.00		3,500.00		100%				
15	Utility Relocation Allowance	1	ALL		10,000.00		10,000.00		10,000.00		10,000.00		10,000.00		10,000.00		10,000.00		100%				
											Change Order Totals \$			\$									
											Original Contract and Change Orders			\$	34,375.00								
											Project Totals \$			\$	255,430.00								

Contractor's Application for Payment

Owner:	Town of Lynnville	Owner's Project No.:	
Engineer:	Commonwealth Engineers, Inc.	Engineer's Project No.:	W23068
Contractor:		Contractor's Project No.:	
Project:	S.R. 61 Water Line Relocation		
Contract:	S.R. 61 Water Line Relocation		
Application No.:	3	Application Period:	From 10/01/2024 to 1/31/2025
		Application Date:	1/17/2025

1.	Total Value of Original Contract Work Completed This Estimate Period:	\$.00
2.	Total Value of Change Order Work Completed This Estimate Period:	\$	0.00
3.	Total Net Contract Work Completed This Estimate Period:	\$	34,375.00.00
4.	Total Value of Stored Materials From <u>PREVIOUS</u> Pay Estimate:	\$	\$0.00
5.	Total Value of Stored Materials For <u>THIS</u> Pay Estimate Period:	\$	\$0.00
6.	Net Increase/Decrease For Stored Materials on This Pay Estimate:	\$	\$0.00
7.	Total Value of ALL Work Completed & Stored Material This Estimate Period (Line 3 + Line 6):	\$	\$0.00
8.	Total Value of Retainage (ESCROW) Payment This Estimate Period @ 5%:	\$	34,375.00
9.	Total Amount Due to Contractor This Estimate Period:	\$	45,427.75

Task Order

In accordance with Paragraph 1.01 of the Agreement Between Owner and Engineer for Professional Services – Task Order Edition, dated January 4, 2016 ("Agreement"), Owner and Engineer agree as follows:

1. Specific Project Data

A. Title: Town of Lynnville, Indiana – SRF PER and SRF AMP

B. Description: Prepare the technical sections of an Asset Management Plan (AMP) for the Wastewater Utility. It is the Owner's intent to be eligible for available funds through the Clean Water State Revolving Fund (CWSRF). In addition, prepare a Preliminary Engineering Report (PER) for submittal to the Indiana Finance Authority (IFA) for project funding.

C. Number of Construction Contracts

The Specific Project is anticipated to be constructed under N/A Construction Contracts.

2. Services of Engineer

Study and Report Services

Engineer shall also provide the following services:

Engineer to assemble an AMP in accordance with IC 5-1.2-10-16 in coordination with the Town and the Town's financial consultant. The Utility must develop and implement an AMP that includes the following minimum requirements:

1. System map
2. An inventory and assessment of system assets
3. Development of an infrastructure inspection, repair, and maintenance plan, including a plan for funding such activities
4. An evaluation and implementation of water and energy conservation efforts
5. An analysis of the customer rates necessary to support the AMP
6. An Audit performed every two years
7. Demonstration of the technical, managerial, legal and financial capability to operate and maintain the system, per the guidelines established by the IFA.

Engineer will complete the Technical and Managerial Sections. The Town's financial consultant will complete the financial sections. Services of the financial consultant are not part of this agreement. Engineer will assemble all sections into a final document.

Engineer shall prepare a Preliminary Engineering Report (PER) for submittal to the Indiana Finance Authority (IFA) to apply for project funding.

- Design Services
- Bidding or Negotiating Services
- Construction and Commissioning Services
- Resident Project Representative Services
- Other Services
- Additional Services

Part 6 of Exhibit A is incorporated by reference unless otherwise noted.

3. Owner's Responsibilities

Owner shall have those responsibilities set forth in Article 2 and in Exhibit B, subject to the following: Not applicable.

4. Times for Rendering Services

<u>Phase</u>	<u>Completion Date</u>
<u>Preliminary Engineering Report (PER)</u>	<u>April 1, 2025</u>
<u>Asset Management Report (AMP)</u>	<u>April 1, 2025</u>

5. Payments to Engineer

A. Owner shall pay Engineer for services rendered as follows:

<i>Category of Services</i>	<i>Compensation Method</i>	<i>Lump Sum, or Estimate of Compensation for Services</i>
Basic Services (Exhibit A)		
Study and Report – PER and AMP	Lump Sum	\$50,000.00

B. The terms of payment are set forth in Article 4 of the Agreement and in Exhibit C.

6. Consultants: N/A

7. Other Modifications to Agreement:

A. Article 8.04.A., "Engineer's Certifications", of the Agreement is hereby amended to include the following:

"4. Pursuant to Indiana Code 22-5-1.7-11, the Engineer entering into this Agreement with the Owner is required to enroll in and verify the work eligibility status of all its newly hired employees through the E-Verify program. The Engineer is not required to verify the work eligibility status of all its newly hired employees through the E-Verify program if the E-Verify program no longer exists.

The Engineer hereby certifies to the Owner that the Engineer does not knowingly employ an unauthorized alien. The Engineer further affirms that, prior to entering into its Agreement with the Owner, the Engineer has enrolled in and agrees to verify the work eligibility status of all its newly hired employees through the E-Verify program.

The Engineer shall provide to Owner a sworn affidavit on an annual basis or as requested by the Owner.

5. Pursuant to Executive Order 13846, the Engineer hereby certifies to Owner that Engineer is not engaged in Investment Activities in Iran."

8. Attachments:

- None

9. Documents Incorporated By Reference: Exhibit A, B & C.

10. Terms and Conditions: Execution of this Task Order by Owner and Engineer shall make it subject to the terms and conditions of the Agreement (as modified above), which Agreement is incorporated by this reference. Engineer is authorized to begin performance upon its receipt of a copy of this Task Order signed by Owner.

Lynnville Park Lease Agreement - Gibson

This Lease Agreement made and entered into on this 21st day of January 2025 by and between **THE LYNNVILLE TOWN COUNCIL**, the Park Authority for the Town of Lynnville, Warrick County, Indiana (hereinafter referred to as "LESSOR") and Jay J Sullivan and Tina K Sullivan (hereinafter referred to as "Lessee").

For and in consideration of the mutual covenants and agreements hereinafter set forth, the Lessor does hereby lease, let rent and demise unto the Lessee and the Lessee does hereby lease and rent from the Lessor the following described real estate in Gibson County, Indiana, to-wit:

Lot # 89

Located at: 12919 E 1025 S, Oakland City, IN 47660

Subject to a utility easement ten (10) feet in width along the front and back lines and five (5) feet in width along the side lines of the above described real estate; subject to the possibility of reverted to Peabody Coal Company, in the event the realty of which the above described real estate is a part ceases to be used for public park and recreation purposes; and further subject to certain reservations and exceptions held by Peabody Coal Company, through its predecessors in interest; all as provided for in a special Warranty Deed dated July 15, 1964, and recorded on July 28, 1964, at 8:05am in the office of the Recorder of Warrick County, Indiana as Instrument #25833.

The terms and conditions under which the demised premises are leased are as follows:

1. **Term** Lease term shall run for one (1) year, from July 1, 2024, through June 30, 2025, together with the opportunity of the Lessee to renew the lease as set forth in paragraph 3.
2. **Contact Information** If any of the information contained in the Lessee Information Sheet provided to Lessor upon execution of the Lease should change, Lessee shall notify Lessor of such changes or any changes within **Thirty (30) days** of the change
3. **Rental** Lessee agrees to pay to the Lessor, as rent, the sum of **One thousand one hundred eight and 80/100 (\$1,108.80)** plus **1/27th** of Lynnville Park's **Gibson County property taxes** per each one (1) year term, subject to any adjustments to the rental amount during future renewal years as set forth in paragraph 3. If the initial period of the lease is for less than one (1) year, the Lessee agrees to pay the Lessor, as rent, a pro-rated amount of **ninety-eight and 02/100 (\$98.02)**, based on annual rent for the initial one (1) year term, due upon the execution of the Lease Agreement. Any subsequent renewal by a Lessee of lease term, as set forth in paragraph 3, shall require payment by Lessee of the annual rental prior to the expiration date of the one (1) year lease term. In the event any subsequent annual lease rental is overdue for a period of thirty (30) days, the Lessee shall pay a late charge of **Thirty-Five dollars (\$35.00)** per lot. In the event that any subsequent annual lease rental is overdue for a period of sixty (60) days, the Lessee shall pay an additional late charge of **Thirty-Five dollars (\$35.00)** per lot. In the event that any subsequent annual lease rental is overdue for a period of ninety (90) days, the Lessee shall pay an additional late charge of **Thirty-Five dollars (\$35.00)** per lot. In the event that any subsequent annual lease rental is overdue beyond 90 days the lease shall terminate.
4. **Insufficient Fund Payments** If any payment is returned by the institution upon which it is drawn due to insufficient funds in the account, then the Lessor may at its discretion immediately

LYNNVILLE PARK RACE AGREEMENT

Lynnville, IN

I, Alan Staples representing SIGPS RACE, wishes to enter the following contract with Lynnville Park for the event held April 26, 2025 – April 27, 2025

1. All campers must have reservations and must be on regular camping sites.
 - a. **One (1)** camper/RV per W/E/S and W/E site only
 - b. **Two (2)** tents per primitive site only
 - c. **Two (2)** vehicles per site only
 - d. No camping will be allowed outside of regular camping sites.
 - e. Over-flow camping and additional camping sites will **ONLY** be approved by the Park Superintendent and in designated areas with additional camping charge.
 - f. Over-flow and additional camping sites not listed in Section 17 (d) of this Lynnville Park Race Agreement are not included and will be an additional camping charge.
2. Campsite check out is 5:00pm Sunday, April 27, 2023. If campers have not checked out by 5:00 an extra night will be charged
3. All fires must be inside fire rings in designated areas only.
4. Pets must ALWAYS be leashed.
5. All pet waste **MUST** be picked up and disposed of properly, not left on the ground.
6. Quiet hours in Lynnville Park are from 10pm-7am.
7. No generators are allowed to operate during quiet hours.
8. Parking in designated areas **ONLY**. Under **NO** circumstances are any roads to be blocked unless pre-approved by Park Superintendent.
9. The speed limit is 10mph throughout the entire park, with the exception of the actual race.
10. Motorcycles, ATVs and UTVs are **ONLY** allowed in campsites for parking.
11. Motorcycles, ATVs and UTVs are **ONLY** to be operated inside Lynnville Park at the designated race time of this event unless pre-approved by Park Superintendent.
12. Race sponsors must provide proof of insurance for this event to Park Superintendent **PRIOR** to race event weekend.
13. Race sponsors must provide adequate toilets for the number of guests/participants/spectators expected to attend each day of the race weekend event.
14. Race sponsors must dispose of **ALL** trash left by participants and spectators of the race event.
15. Race sponsors must repair all ground, road, etc. damaged during race events.
16. Any guests/participants/spectators of this race event not in compliance with the rules of Lynnville Park will be asked to leave the grounds.
17. Race Sponsor/registered camper for camp site is responsible for the action and conduct of your group.
18. Possession of fireworks, firearm and bow & arrows are **strictly prohibited** in Lynnville Park
19. Lynnville Park Race Agreement includes as follows:
 - a. Use of Recreational building
 - b. Use of Shelter House
 - c. Use of grounds for purpose of race event.
 - d. Use of primitive camp sites #344; # 346; 347; #348; #349, Friday, April 26, 2025, 2:00pm through Sunday, April 27, 2025, 5:00pm (map included)
 - e. Over-flow and additional camping sites **not listed** above are not included and will be an additional camping charge.

20. Fees include (revised January 2019):

- a. \$2,000.00 plus a deposit of \$500.00. The deposit will be refunded once the grounds, buildings and campsites have been inspected by the Park Superintendent and determined all are in acceptable condition.
- b. Lynnville Park reserves the right to collect all camping fees not included in this agreement.
- c. Race sponsors reserve the right to collect gate/entry fees of participants and spectators of this race event.

21. All Race Officials are to wear orange safety vests and all Lynnville Park employees are to wear employee uniform shirts during the race event.

Lynnville Park would like to welcome you and hope you have a safe and enjoyable stay with us.

Sponsor:

Sponsor:

Signature

Date

Signature

Date

Printed Name

Printed Name

*****ATTACH COPY OF EACH SPONSOR'S ID*****

Park Superintendent:

Town Council:

Katherine Hofmann

Rachel Tizzer, Member

Doris Horn, Member

David Goldenberg, President

Payment Received:

Deposit \$500.00 - Date Received: _____ Payment Type: _____ Employee: _____

Rental \$2000.00 - Date Received: _____ Payment Type: _____ Employee: _____

Deposit Refund:

Inspection Date: _____ Employee Inspected by: _____ Refund: Y / N

Reason if Refund was not returned: _____

Refund returned.

Date: _____ Amount: \$ _____ Payment Type: _____ Employee: _____

LNB COMMUNITY BANK

January 15, 2025

Town of Lynnville
Town Board
207 Main Street
Lynnville, IN 47619

Dear David, Doris and Rachel:

On behalf of everyone at LNB Community Bank I would like to express our appreciation for the trust and partnership that the Town of Lynnville has placed in us over the years. As part of our ongoing commitment to better serve our community partners LNB Community Bank is pleased to offer an increase in the interest rates on the Town of Lynnville's current accounts. This positive change is aimed at helping the town earn more from its deposits, which we believe can contribute significantly to the town's financial health.

This increased interest rate aligns with our goal to ensure that the town's resources are working as efficiently as possible. We are confident that this enhanced rate will yield a meaningful return on the town's funds while continuing to provide the accessibility and flexibility that are critical to municipal financial management.

As a local financial institution, we understand the importance of supporting the community in every way possible. By continuing to bank with LNB Community Bank, the Town of Lynnville helps reinvest in the local economy. LNB Community Bank currently has over 38 Million dollars in originated mortgages in the Lynnville Zip Code on our books. We provide loans, and services that benefit residents and taxpayers. This keeps money circulating within our town which benefits everyone. Keeping business local is crucial to our community's financial health.

The funds held with us are not just an asset to your account, but an integral part of a broader effort to foster economic growth, create jobs, and support community initiatives within the Town of Lynnville. Staying with us ensures that the town's financial resources continue to contribute directly to the local economy.

Over the years, LNB Community Bank has developed a deep understanding of the town's unique financial needs. Our team is dedicated to providing personalized service tailored to meet the specific requirements of municipal accounts. The trust and efficiency we have established are invaluable in managing the town's daily operations, and we remain committed to ensuring that our services continue to exceed expectations.

Lynnville	Chandler	Newburgh	Boonville
P: 812-922-3231	P: 812-925-3326	P: 812-858-1605	P: 812-897-4700
F: 812-922-3233	F: 812-925-2207	F: 812-858-1640	F: 812-897-4725

We are confident that continuing our banking relationship will serve the best interests of the Town of Lynnville both financially and socially. The new interest rate offering, combined with the ongoing support for local economic growth, ensures that this partnership remains mutually beneficial.

Below is the proposed interest rates for your current accounts at LNB Community Bank. We would be honored to continue serving the town and look forward to discussing how we can further support the town's financial goals. Should you have any questions or wish to discuss this proposal in more detail, please do not hesitate to contact me directly.

Thank you for your continued trust and partnership.

Sincerely,



Bradley K Pemberton

President

LNB Community Bank

812-922-3231

bpemberton@lnbcorp.com

**Interest Rate Increase Checking/Money Market
Proposal for Town of Lynnville
January 16, 2025**

CURRENT ACCOUNTS

XXX0688 Hart Township Fire Territory	1.75%
XXXX981 Community Center	1.75%
XXXX4271 Lynnville Park	1.75%
XXXX0008 General	2.75%
XXXX Utility Operations	2.75%
XXXX Payroll	1.75%

This proposal is good for 30 days.

Lynnville Clerk

From: David Goldenberg
Sent: Thursday, January 30, 2025 8:51 PM
To: Lynnville Clerk
Subject: Re: [External]Metzger - CCMG Estimates - 2025

Terry lane - did you look at the street settling issue??

[Get Outlook for iOS](#)

From: David Goldenberg <council1@townoflynnville.com>
Sent: Thursday, January 30, 2025 8:43:34 PM
To: Lynnville Clerk <clerk@townoflynnville.com>
Subject: Fw: [External]Metzger - CCMG Estimates - 2025

[Get Outlook for iOS](#)

From: Tim Metzger <tim@metzgerasphalt.com>
Sent: Thursday, January 30, 2025 8:33:55 PM
To: David Goldenberg <council1@townoflynnville.com>; Rachel Titzer <council2@townoflynnville.com>
Subject: [External]Metzger - CCMG Estimates - 2025

Attached are the individual estimates requested. I will send the summary in a second email.

Thank you,

Tim Metzger

Metzger Construction Co., Inc.
655 N Center Rd
Boonville, IN 47601

PH 812.925.7544
FX 812.925.7545

CAUTION: This email originated from outside of the organization. Do not click links or open attachments unless you recognize the sender and know the content is safe.

Lauri Stockus

From: BSM Permits <permits@bsmgroups.com>
Sent: Tuesday, January 7, 2025 9:49 AM
To: Lauri Stockus
Subject: [External]ROW Permit Application 22-00830-22 -RDOF Node EV05E
Attachments: City 22-00830-22 UG Petersburg Rd.pdf

Good Morning,

We had previously submitted a ROW Permit Application to Warrick County. Warrick County stated that this work is within the Town of Lynnville. We are unaware of your permitting process. Could you provide us with your permitting process and any contacts we will need to keep on file?

Thank you,

Megan Bailey

Lead Permit Clerk
(812)271-2407



225 Mulberry St.
Seymour, IN 47274

CAUTION: This email originated from outside of the organization. Do not click links or open attachments unless you recognize the sender and know the content is safe.

Charter

COMMUNICATIONS

RDOF NODE EV05E

Petersburg Rd, Lynnville, IN



- SHEET INDEX**
- 1 - COVER SHEET
 - 2 - NOTES / LEGEND
 - 3 - RAKEOFF
 - 4 - MOT SHEET
 - 5 - 6 - DETAIL SHEET
 - 7 - PLACEMENT SHEET



TOWN OF LYNNVILLE
RIGHT OF WAY PERMIT

PROJECT:
RDOF NODE EV05E
LOCATION: Petersburg Rd
(Hartsville City, Hart Township)

SCOPE OF WORK:
Approximately 1130 (ft) of New Underground Cable
Candial Depth: 36" (ft) Standard / Unless Specified

DESIGN: K08 0107/2065
CONST SET: XXX
REV 1: XXX
PERMIT: XXX
AS BUILT: XXX

PERMITS REQUIREMENTS:
RIGHT OF WAY: REQUIRED
MOT: NOT REQUIRED
RAILROAD: NOT REQUIRED

BSM CLIENT #
22-0885-22/124891
SHEET: 1 OF 7



	Flow and Place Bore and Place Duct 1 - 1 1/4"	Cut and Place Duct 1 - 1 1/4"	Cut and Place Slow and Pull Coax Duct 2 - 2"	Work Within Right of Way	Place Vault 30"x48"x36"	Place Pedestal	Place Power Supply	Delash/Relash	Place New Strand and Fiber	Place New Strand and Coax	Overlash New Fiber to Existing Strand	Overlash New Coax to Existing Strand
SHEET 7	1129	-	-	1129	-	-	-	-	-	-	-	-
Total	1129			1129								



BSM
Groups LLC
443-273-1400

TOWN OF LYNNVILLE
RIGHT OF WAY PERMIT

PROJECT:
RD OF MOOSE EROSE
LOCATION: Palmsburg Rd
Lynnville, IN
(Warlick, Cole, Hart, Teweap)

SCOPE OF WORK:
Approximately 1130' (ft) of New Underground Cable
Conduit Depth: 36" (in) Standard / Unless Specified

DESIGN: NOS 01/07/2023
CONST SET: XXX
REV 1: XXX
PERMIT: XXX
AS BUILT: XXX

PERMIT REQUIREMENTS:
RIGHT OF WAY: REQUIRED
INDOT: NOT REQUIRED
RAILROAD: NOT REQUIRED

BSM / CLIENT #
22-080-27 / 122489

SHEET 3 **OF** 7



Flagging Procedures

- Properly Trained Flaggers**
- provide messages in crews as shown;
 - allow time and distance for crews to react;
 - coordinate with other flaggers
- Properly Equipped Flaggers**
- approved safety vest;
 - paddles are not to be used for a separate instrument;
 - approved Personal Protective Equipment;
 - highly visible, but not reflective, clothing;
 - highly visible, but not reflective, reflective material, not for better visibility;
 - no reflective safety equipment

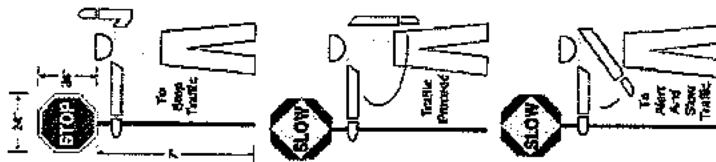

- Proper Flagging Station**
- good approach sight distance;
 - highly reflective;
 - never stand in moving traffic lane;
 - always in line with approach

- Proper Advance Warning Sign**
- always use warning sign;
 - allow extra distance from sign;
 - remove sign if not flagging

Flaggers should be trained in proper procedures for placement of signs and flags. Flaggers should be trained in proper procedures for placement of signs and flags. Flaggers should be trained in proper procedures for placement of signs and flags.

Lane Closure on a Two-Lane Road When Flagging Operations

SDOT Form No. 600-001-01-01-01-01-01

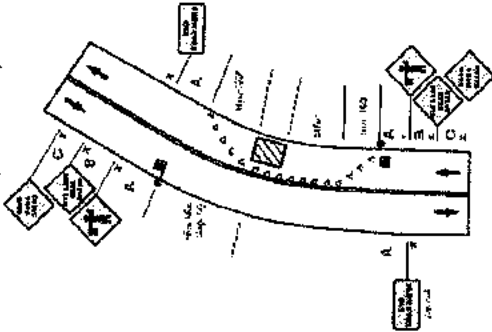

Notes:

1. No flagger or flaggers shall use approved flagging procedure standards for SDOT and for State of Maine.
2. Public Safety Division is responsible for providing training for flaggers. All flaggers shall be trained in proper procedures for placement of signs and flags. Flaggers shall be trained in proper procedures for placement of signs and flags.

Work	Start	Stop	MA
Location	Time	Time	Station
1	08:00	10:00	101
2	08:00	10:00	102
3	08:00	10:00	103
4	08:00	10:00	104
5	08:00	10:00	105
6	08:00	10:00	106
7	08:00	10:00	107
8	08:00	10:00	108
9	08:00	10:00	109
10	08:00	10:00	110
11	08:00	10:00	111
12	08:00	10:00	112
13	08:00	10:00	113
14	08:00	10:00	114
15	08:00	10:00	115
16	08:00	10:00	116
17	08:00	10:00	117
18	08:00	10:00	118
19	08:00	10:00	119
20	08:00	10:00	120

70

70



TOWN OF LYNNVILLE
RIGHT OF WAY PERMIT

PROJECT:
ROADSIDE PAVEMENT PD
LYNNVILLE
(March 2017, Hill Township)

SCOPE OF WORK:
Approximately 1130' (ft) of New Underground Cable
Conduit Depth: 36" (in) Standard / Unless Specified

PERSON: 005 01/07/2025
CONST. SET: XXX
REV: XXX
PERMIT: XXX
AS BUILT: XXX

PERMIT REQUIREMENTS:
RIGHT OF WAY: NOT REQUIRED
INDOT: NOT REQUIRED
RAILROAD: NOT REQUIRED

BSM CLIENT #
22-0000-227124891
SHEET: 4 OF 7

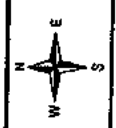

TYPICAL DETAIL
SHAPE TRANSITION AREA ON
CORNER OF MAIN COURSE

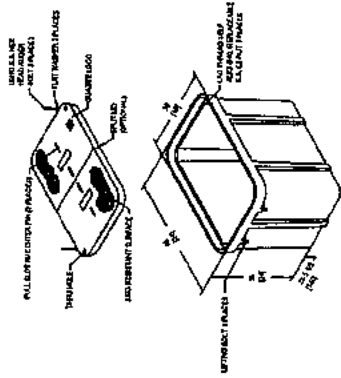

TYPICAL DETAIL
INTERIOR END OF MAIN ROAD

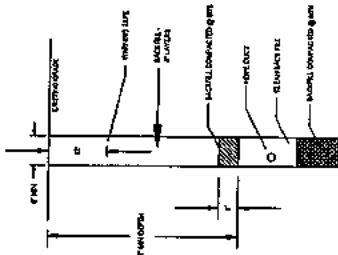

TYPICAL DETAIL
FINISHED FORMATION

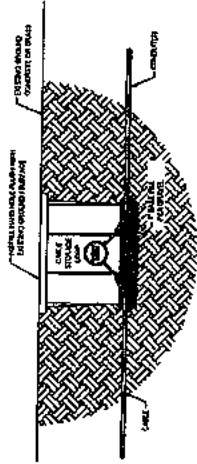

TYPICAL DETAIL
TOP OF MAIN ROAD

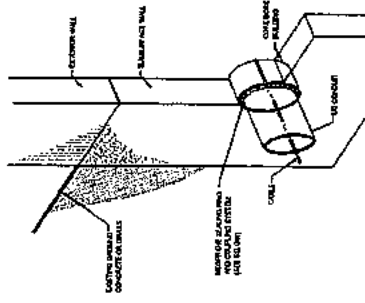

TYPICAL DETAIL
UPPER FORMATION

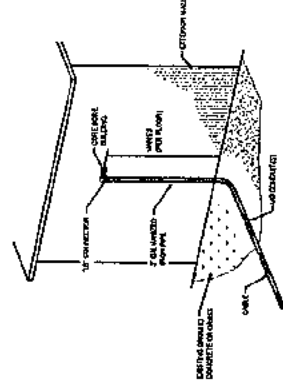

TYPICAL DETAIL
LIGHT TEST ROAD

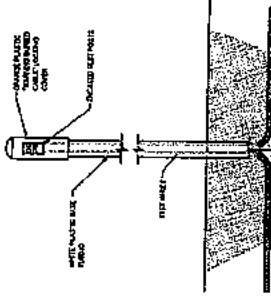

TYPICAL DETAIL
MAIN ROAD

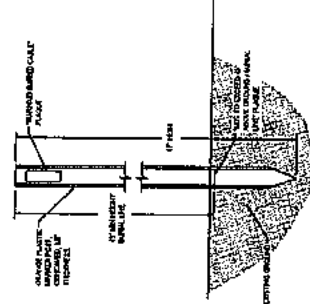

TYPICAL DETAIL #5
OPEN ROAD CUT

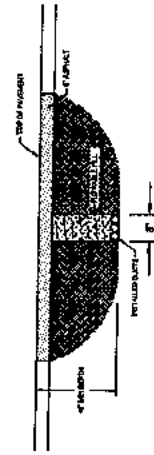

TYPICAL DETAIL
CORNER DETAIL

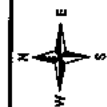
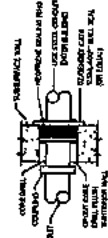

BSM GROUPS LLC
 22-0089-22 / 1224691
 SHEET: 5 OF 7

PERMITS REQUIREMENTS:
 RIGHT OF WAY: NOT REQUIRED
 INDOT: NOT REQUIRED
 RAILROAD: NOT REQUIRED

DESIGN: N08 01/07/2025
 CONST SET: XXX
 REV 1: XXX
 AS BUILT: XXX

SCOPE OF WORK:
 Approximately 1100 (ft) of New Underground Cable
 Conduit Depth: 36" (n) Standard / Unless Specified

PROJECT:
 ROOF NODE EXPOSE
 LOCATION: Peasbarg Rd
 Lynnville, IN
 (Warrick City, Hart Township)

TOWN OF LYNNVILLE
 RIGHT OF WAY PERMIT



PLOW PROFILE

VIBRATORY PLOW AND REEL

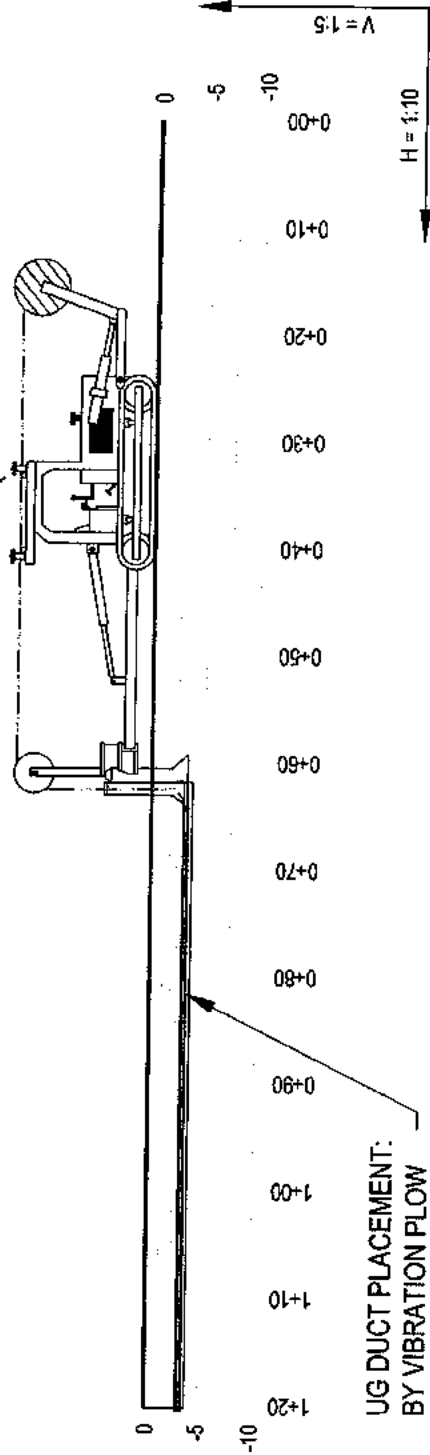

UG DUCT PLACEMENT:
BY VIBRATION PLOW
PLACE 1 - 1 1/4" DUCT
AND FIBER OPTIC CABLE
AT A MINIMUM DEPTH OF 30"

PROJECT:
ROOF NODE EVIDE
LOCATION: Petersburg Rg
Lynnville, TN
(Warren City, Hart Twship)

TOWN OF LYNNVILLE
RIGHT OF WAY PERMIT



SCOPE OF WORK:
Approximately 1130' (ft) of New Underground Cable
Cable Depth: 36" (ft) Standard (Unless Specified)

DESIGN: RGS 0107/2025
PLANS SET: XXX
PERMIT: XXX
AS BUILT: XXX

PERMIT REQUIREMENTS:
RIGHT OF WAY: REQUIRED
INDOT: NOT REQUIRED
RAILROAD: NOT REQUIRED

BSM #1 CLIENT #
22-0009-02 / 124(8)

SHEET: 6 OF 7



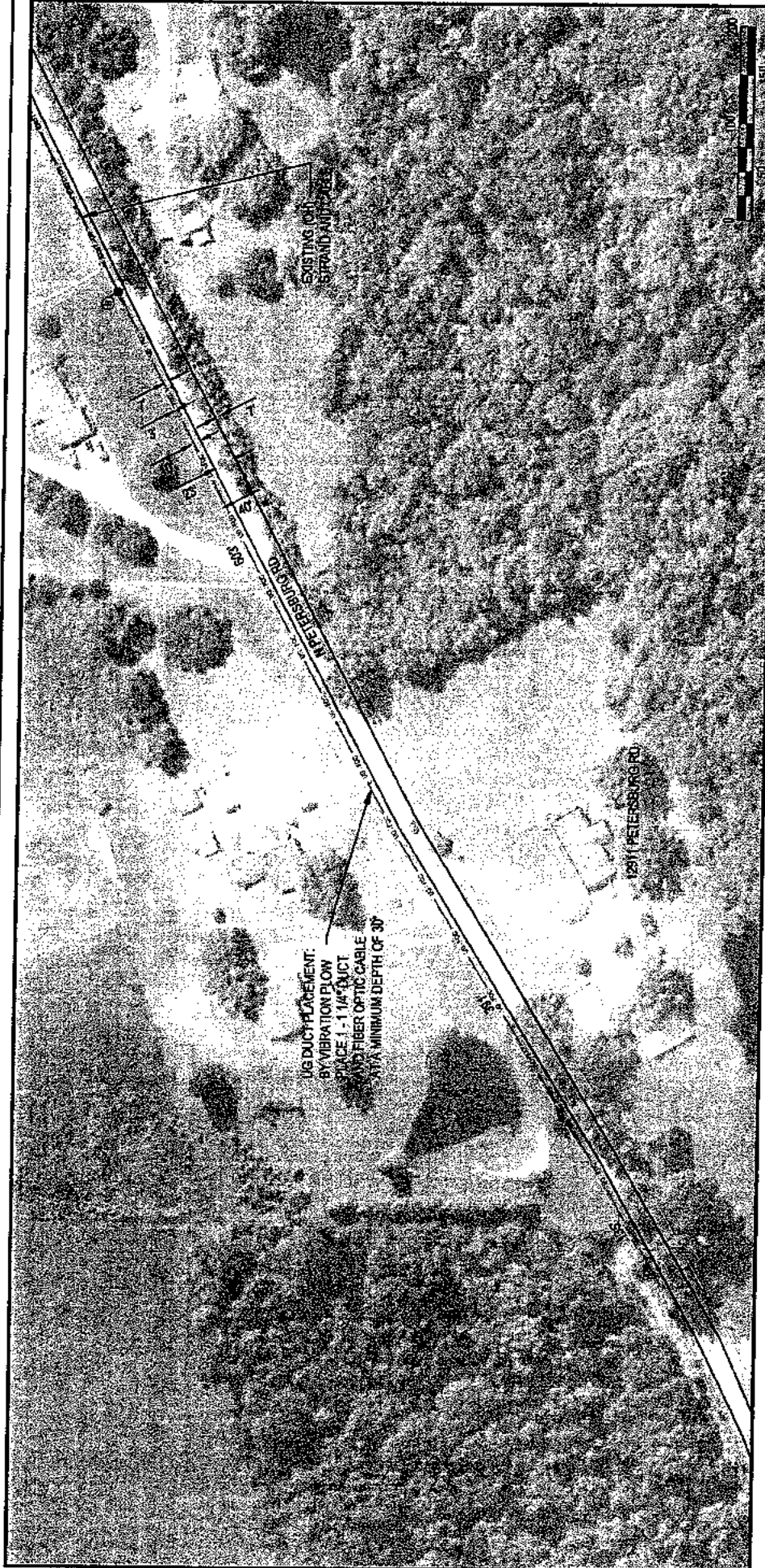

Place and Place Bore and Place Duct 1 - 1 1/4"	Cut and Place Duct 1 - 1 1/4"	Cut and Place Duct 2 - 2"	Coax	Fiber	Work Within Right of Way	Place Vault 30"x48"x36"	Place Pedestal	Place Power Supply	Delash/Relash	Place New Strand and Fiber	Place New Strand and Coax	Overlash New Fiber to Existing Strand	Overlash New Coax to Existing Strand
SHEET 7	1129	-	-	1129	1129	-	-	-	-	-	-	-	-

PROJECT:
 BOF XODGE EVOBE
 LOCATION: Petersburg Rd
 Springfield
 (Warrens City, Hart Township)

**TOWN OF LYNNVILLE
 RIGHT OF WAY PERMIT**

**BSM
 Groups LLC**
 423-274-2400

SCOPE OF WORK:
 Approximately 1130' (ft) of New Underground Cable
 Conduit Depth: 36" (ft) Standard / Unless Specified

DESIGN: NOS 61671/025
 SET: XXX
 REV 1: XXX
 PERMIT: XXX
 AS BUILT: XXX

PERMITS REQUIREMENTS:
 PERMIT OF WAY: REQUIRED
 INDUSTRY: NOT REQUIRED
 ROAD: NOT REQUIRED

BSM CLIENT #
 22-0060027 / 220681

SHEET: 7 OF 7

Community Center Coordinator

Name

Objective

Attracting and acquiring new reservations and generating income for the Town of Lynnville Community Center

Responsibilities

- Conduct on-site walk-through appointments
- Respond to inquiries and booking reservations
- Obtain signed contracts from clients and tracking all event documentation including payments and permits
- Maintain and report financial records
- Maintain, manage and report information on the event calendar for employees and Town Council
- Create and maintain inventory list
- Manage the electronic sign
- Assist in establishing the website
- Market and advertise the Community Center, including social media
- Create venue brochures
- Create rental add-on packages
- Develop fundraising event plans, timelines and schedules
- Prepare fundraising event
- Be knowledgeable on all aspects of the Community Center
- Maintain professionalism

Compensation

- Salary: \$12,000.00 annually paid bi-weekly

Benefits

- Flexible Independent scheduling
- Hybrid Work (home and the Community Center)
- Ability to contact town representatives and reliable volunteers as needed

This is a "Research Year" for this position and responsibilities may be adjusted as needed. We are all a team focused on building the Community Center for the greater good.

X _____
(Name) Date

Attest:

X _____
Lauri Stockus, Clerk-Treasurer Date

X _____
Doris Horn, Town Council Member Date

X _____
Rachel Titzer, Town Council Member Date

X _____
David Goldenberg, Town Council President Date

T TORIC ENGINEERING

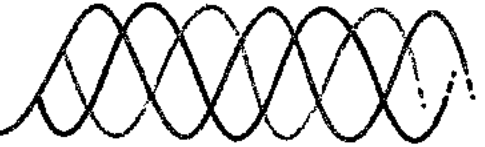

January 7, 2025

RE: Lynnville WWTP

Dear Mr. Marcus,

Thank you for the opportunity to quote upgrading the SCADA Computer for the Lynnville WWTP. Toric Engineering's price for this work is **\$26,983.00**. This price includes following:

- **Computer and Software:**
 - Computer, Dell tower, Windows 11
 - Monitor, 24"
 - GE iFix runtime software license, 150-point
 - IGS communication driver
- **DECP-1 Control Panel Modifications:**
 - Tosibox VPN remote connection router w/ mobile client
 - Installation
- **Engineering Services Includes:**
 - On-site startup
 - On-site training
 - One (1) year warranty on parts and labor
 - SCADA graphics, DECP-1 control panel
 - SCADA graphics, SBR control panel
 - SCADA graphics, water system control panel
- **Excludes the following items:**
 - Alarm dialers (existing)
 - Conduit and wire (existing)

Allow ten (10) to twelve (12) weeks for delivery.

Sales tax not included. Please provide Tax Exempt Form.

Control Panels are not subject to return.

Payment Terms: Net 30 days; equipment PO only

This quote is valid for 30 days.

Please call with any questions or comments.

Sincerely,

Nathen Burkhart
Toric Engineering



QUOTATION		
DATE	NUMBER	PAGE
2/15/2024	0002045	1 of 1

UN-APPROVED

B NEU003
 I NEWBURGH UTILITIES
 L PO BOX 100
 L NEWBURGH, IN 476290100
 T US
 O

S NEWBURGH UTILITIES
 H PO BOX 100
 I NEWBURGH, IN 47629-0100
 P
 T
 O

Accepted By: _____
 Company: _____
 Date: _____
 PO#: _____
 Ship To: _____

ATTENTION:
 MARCUS JOLLY

MJOLLY@NEWBURGH-IN.GOV

WE ARE PLEASED TO PROPOSE THE FOLLOWING FOR YOUR CONSIDERATION:

CUSTOMER REF/PO#			JOB TITLE		SLP	SHIPPING TYPE	TERMS: NET 30	
LYNNVILLE			LYNNVILLE WWTP, SCADA		B&L/BJG	FREIGHT ALLOWED		
QTY	PART	DESCRIPTION				UNIT PRICE	EXTENDED	

1	SCADA COMPUTER	W/REMOTE LOG IN FEATURE	\$34,343.00	\$34,343.00
---	----------------	-------------------------	-------------	-------------

- Computer and Software:
- Computer w/24" monitor
 - GE iFix software license, 150-point
 - Remote VPN connection router added to DECP-1 Panel

- Engineering Services Includes:
- On-site startup & Training, 5 days included
 - One (1) year warranty
 - SCADA graphics

- Excludes the following Items:
- Electrical installation provided by others.
 - Alarm dialer provided by owner.

Lead time - 12-15 weeks after approval.

This quote is subject to and incorporates by reference BL Anderson Terms & Conditions and Customer Warranty available at www.blanderson.com which will be provided by email upon written request. Buyer expressly agrees to the provisions set forth in the Terms & Conditions and Customer Warranty posted on BL Anderson Company's website.

QUOTE VALID FOR 60 DAYS. CREDIT CARD PAYMENTS ARE SUBJECT TO AN ADDITIONAL 3% CHARGE NO TAXES OF ANY KIND ARE INCLUDED IN THIS PROPOSAL

SUBTOTAL: \$34,343.00

4801 Tazer Drive Lafayette, IN 47905 - Phone: 765-463-1518 - Fax: 765-446-8390

www.blanderson.com



LAI, Ltd.

5400 Newport Drive • Suite #10 • Rolling Meadows, Illinois 60008 • 847/392-0990 • FAX 847/392-1095

QUOTATION SHEET

To: Marcus Jolly From: Peter J. Lynch
Lynnville
mjolly@newburgh-in.gov
Phone: _____ Date: January 10, 2025
Re: Lynnville SCADA CC: Job File

- Urgent For Review Please Comment Please Reply As Requested

Comments:

Marcus

Thank you for the opportunity to propose on your SCADA, Controls and Instrumentation upgrades. After review of your project we are unable to bid at this time due to current workloads with our control and instrumentation suppliers.

Please keep us in mind for future opportunities.

Best Regards,

Peter J. Lynch

LYNNVILLE TOWN PRIORITIES

TOWN HALL

Priority	Costs Est.	Approved	Anticipated Completion	Possible Funding
1. new flooring		Y		Bond
2. kitchen cabinets		Y	1/10/2025	Bond
3. outside lights	20000	Y	2/1/2025	Bond
4. furniture upgrades	22,000	pending		Bond
5. recording of meetings	50,000	mandatory		Bond
6. signage back door	100	pending		Bond

LYNNVILLE PROPER

1. streets	200,000	pending		Grant
2. street lights - additional	20000	pending		Bond
3. solar speed limit signs - main	8000	pending		Bond
4. solar speed limit signs - High School	8000	pending		WSC?
5. replacement of street signs	?	pending		Bond
6. water line/sewer replacements	100000 per yr - 5 yrs	pending		Utility Bond
7. main lift station	5000000	pending		Utility Bond
8. outdoor tables	3000	pending		Bond
9. gazebo	35000	pending		Bond
10. landscaping	10000 ?	pending		
11. plants/fixtures lights on main	1000 ?	pending		
12. Christmas decorations main	???	pending		

Community Center

1. repair flooring	?	pending		INSR
2. bathroom updates	6500	pending		
3. storage wall-hide chairs/tables	5000 ?	pending		
4. commercial Oven range combo	5000 ?	pending		
5. storage units	800	pending		
6. christmas tree/ornaments/etc	350	pending		

7	additional chandeliers	?		pending	
8	moving cart		250	pending	
9	landscaping		5000	pending	
10	misc items for kitchen		2500 ?	pending	
Park					
1	Kubota repair		5000 ?	pending	Park
2	rec bldg. painting /lights		1000	pending	Park
3	road valley ditching		10000 ?	pending	Park
4	WiFi and cameras		5000 ?	pending	
5	paving parking lots		7500 ?	pending	Park
6	rock fill roads		10000 ?	pending	Park
7	Signage/misc for fountain area		2000	pending	Park
8	John boat		1000 ?	pending	Park
9	tractor		40000 ?	pending	Park
10	additional kayaks		6000	pending	Park
11	facilities/upgrades new area	????????			
12	trail house updates??	????????			

ANNEX					
1	HVAC			approved	Bond
2	bathroom/ramp/door upgrades			approved	Bond
3	new windows in back		4500 ?	pending	
4	new flooring in back		5000 ?	pending	
5	fix front door		1500 ?	pending	
6	gutters???	???		pending	
7	rock for parking areas		3000 ?	pending	
Water Tower					
1	computer		1000 ?	pending	

Grounds/Shop ????

Marshall ????

Personal

Park manager

Workers for the park

Community Center worker

Grant Writer

These are potential list to start discussions on and to help in prioritization.

David Goldenberg 1-1-2025



Paul D. Joyce, CPA
State Examiner

INDIANA STATE BOARD OF ACCOUNTS

302 WEST WASHINGTON STREET
ROOM E418
INDIANAPOLIS, INDIANA 46204-2769
Telephone: (317) 232-2513
Fax: (317) 232-4711
www.in.gov/sboa

**STATEMENT OF ENGAGEMENT COST
THIS IS NOT AN INVOICE FOR PAYMENT!**

Town of Lynnville Wastewater Utility
PO BOX 99
LYNNVILLE IN 47619

ENGAGEMENT PERIOD: January 1, 2020 to December 31, 2023

BILLING DATE: 1/9/2025

	DAYS	RATE	TOTAL
LOCAL FUND	14.10	\$ 968.00	\$ 13,648.80

PLEASE NOTE FOR FEDERAL GRANTS SHOWN:

If any of the federal programs have money available and if the federal program allows you to do so, you may transfer the amount indicated above from the particular fund to the general fund.

THIS IS NOT AN INVOICE FOR PAYMENT!



Paul D. Joyce, CPA
State Examiner

INDIANA STATE BOARD OF ACCOUNTS

302 WEST WASHINGTON STREET
ROOM E418
INDIANAPOLIS, INDIANA 46204-2769
Telephone: (317) 232-2513
Fax: (317) 232-4711
www.in.gov/sboa

**STATEMENT OF ENGAGEMENT COST
THIS IS NOT AN INVOICE FOR PAYMENT!**

Town of Lynnville Water Utility
PO BOX 99
LYNNVILLE IN 47619

ENGAGEMENT PERIOD: January 1, 2020 to December 31, 2023

BILLING DATE: 1/9/2025

	DAYS	RATE	TOTAL
LOCAL FUND	14.10	\$ 968.00	\$ 13,648.80

PLEASE NOTE FOR FEDERAL GRANTS SHOWN:

If any of the federal programs have money available and if the federal program allows you to do so, you may transfer the amount indicated above from the particular fund to the general fund.

THIS IS NOT AN INVOICE FOR PAYMENT!



Paul D. Joyce, CPA
State Examiner

INDIANA STATE BOARD OF ACCOUNTS

302 WEST WASHINGTON STREET
ROOM E418
INDIANAPOLIS, INDIANA 46204-2769
Telephone: (317) 232-2513
Fax: (317) 232-4711
www.in.gov/sboa

STATEMENT OF ENGAGEMENT COST
THIS IS NOT AN INVOICE FOR PAYMENT!

RECEIVED

Town of Lynnville
PO BOX 99
LYNNVILLE IN 47619

Lynnville Clerk Treasurer

ENGAGEMENT PERIOD: January 1, 2020 to December 31, 2023

BILLING DATE: 1/9/2025

	ASSISTANCE LISTING NUMBER	DAYS	RATE	PROCESS FEE	TECH FEE	TOTAL
LOCAL FUND		14.0	\$ 395.00	\$ 488.83	\$ 768.17	\$ 6,773.83

PLEASE NOTE FOR FEDERAL GRANTS SHOWN:

If any of the federal programs have money available and if the federal program allows you to do so, you may transfer the amount indicated above from that particular fund to the general fund.

For public school corporations only, the transfer can be to the operations fund.

THIS IS NOT AN INVOICE FOR PAYMENT! This statement is being sent to you to provide detail of the engagement costs associated with your unit of government. An invoice for payment has been sent to your county for payment in accordance with IC 5-11-4. Please do not send payment directly.

THIS IS NOT AN INVOICE FOR PAYMENT!



INVOICE

Please Remit To:

State Board of Accounts
302 W. Washington Street
Room E418
Indianapolis IN 46204

Paul D. Joyce, CPA
State Examiner

Page: 1
Invoice No: 000003880
Invoice Date: 01/09/2025
Customer Number: CST000006227
Bill Type: AUD
Payment Terms: Immed Pay
Due Date: 01/09/2025

Bill To:

TOWN OF LYNNVILLE-WATER UTILITY
PO BOX 99
LYNNVILLE IN 47619-0099

AMOUNT DUE: 13,648.80 USD

13,648.80

Note Address Changes Above

Email Address: Clerk-Treasurer@TownofLynnville.com

Amount Remitted

For billing questions, please call 317-232-2513

Line	Adj	Identifier	Description	Quantity	UOM	Unit Amt	Net Amount
1		2020/21/22/23	LYNNVILLE WATER UTIL	1.00	EA		13,648.80

TOTAL AMOUNT DUE : 13,648.80

Please write the invoice number on your check and return the upper portion of this invoice with remittance.

For amounts due from taxing units, the County Auditor will obtain reimbursement by deduction from the next semi-annual settlement of taxes.

Please remit payment via ACH per the enclosed memo.

Any prior balance is past due. If paid, please ignore. Remit within 30 days. Your immediate attention to this matter is appreciated.

If you have questions regarding this invoice, contact Allyson Backus at 317-234-0535 or email billing@sboa.in.gov.

RECEIVED

Lynnville Clerk Treasurer



INVOICE

Please Remit To:

State Board of Accounts
302 W. Washington Street
Room E418
Indianapolis IN 46204

Paul D. Joyce, CPA
State Examiner

Page: 1
Invoice No: 000003881
Invoice Date: 01/09/2025
Customer Number: CST000006228
Bill Type: AUD
Payment Terms: Immed Pay
Due Date: 01/09/2025

Bill To:

TOWN OF LYNNVILLE-WASTEWATER UTILITY
PO BOX 99
LYNNVILLE IN 47619-0099

AMOUNT DUE: 13,648.80 USD

13,648.80

Amount Remitted

Note Address Changes Above

Email Address: *clerk-treasurer@townoflynnville.com*

For billing questions, please call 317-232-2513

Line	Adj	Identifier	Description	Quantity	UOM	Unit Amt	Net Amount
1		2020/21/22/23	LYNNVILLE WW UTIL	1.00	EA		13,648.80

TOTAL AMOUNT DUE : 13,648.80

Please write the invoice number on your check and return the upper portion of this invoice with remittance.

For amounts due from taxing units, the County Auditor will obtain reimbursement by deduction from the next semi-annual settlement of taxes.

Please remit payment via ACH per the enclosed memo.

Any prior balance is past due. If paid, please ignore. Remit within 30 days. Your immediate attention to this matter is appreciated.

If you have questions regarding this invoice, contact Allyson Backus at 317-234-0535 or email billing@sboa.in.gov.

RECEIVED

Lynnville Clerk Treasurer

Town of Lynnville - Reimbursement Policy

Purpose

The purpose of this policy is to establish clear guidelines for the reimbursement of expenses incurred by employees and Council Members of the Town of Lynnville. This policy aims to ensure transparency, accountability, and fiscal responsibility in the use of town funds.

Policy Statement

No reimbursements for expenses shall be made to any Town of Lynnville employee or Council Member without prior written approval from all Town Council Members or acceptance of the expense in an official Town Council meeting.

Scope

This policy applies to all employees and Council Members of the Town of Lynnville.

Procedures

1. **Pre-Approval Requirement:**
 - Any employee or Council Member seeking reimbursement for expenses must submit a detailed request in writing.
 - The request must include a description of the expense, the estimated amount, and the justification for the expenditure.
 - Written approval from all Town Council Members is required before the expense is incurred.
2. **Council Meeting Approval (if applicable):**
 - In the event written approval is not feasible, the reimbursement request must be presented during an official Town Council meeting for discussion and approval.
 - The request must be recorded in the meeting minutes.
3. **Submission for Reimbursement:**
 - Once approval is obtained, the employee or Council Member may incur the expense.
 - Reimbursement requests must be submitted with all relevant receipts and documentation.
 - Requests must be filed within 30 days of incurring the expense.
4. **Non-Compliance:**
 - Any expenses incurred without prior approval or Council acceptance shall not be eligible for reimbursement.
 - Exceptions to this policy will only be considered under extraordinary circumstances and must be approved by a unanimous vote of the Town Council.

Review and Amendments

This policy shall be reviewed annually and may be amended by the Town Council as necessary.

Effective Date

This policy becomes effective immediately upon adoption by the Town Council.

Adopted by the Town Council of Lynnville on January 21, 2025.

****Town of Lynnville Employee Social Media Policy****

****Purpose:****

The purpose of this policy is to provide guidelines for the appropriate use of social media by employees of the Town of Lynnville. This policy is intended to ensure that employees use social media in a responsible manner that upholds the town's values, maintains public trust, and protects confidential information.

****Scope:****

This policy applies to all employees, contractors, volunteers, and elected officials who use social media platforms in any capacity that may reflect on the Town of Lynnville. This includes but is not limited to platforms such as Facebook, Twitter, Instagram, LinkedIn, and any emerging forms of online communication.

****General Guidelines:****

1. ****Professional Conduct:**** Employees must conduct themselves in a professional and respectful manner when using social media. Posts should reflect positively on the Town of Lynnville and should not damage the town's reputation.
2. ****Transparency and Honesty:**** Employees must clearly identify themselves when discussing town-related matters online. Misrepresentation or anonymity in official communications is prohibited.
3. ****Confidentiality:**** Employees must not disclose any confidential, proprietary, or sensitive information about the Town of Lynnville, its employees, or residents.
4. ****Use of Town Resources:**** Use of social media during work hours should be limited to official town business. Personal use of social media should not interfere with work responsibilities.
5. ****Legal Compliance:**** Employees must comply with all applicable laws and regulations, including those related to privacy, harassment, and copyright.

****Official Town Accounts:****

1. Only authorized personnel may create, manage, or post on official Town of Lynnville social media accounts.
2. Content posted on official accounts should reflect the town's mission and values, provide accurate information, and encourage positive engagement with the community.

3. Employees responsible for managing official accounts must monitor and respond to public inquiries in a timely and respectful manner.

****Personal Use of Social Media:****

1. Employees are encouraged to exercise caution and good judgment when using personal social media accounts. Even personal posts may reflect on the town, particularly if the employee is identifiable as a town representative.
2. Employees must not claim to represent the Town of Lynnville on personal accounts unless explicitly authorized.
3. Criticism of town policies or officials should be addressed through appropriate internal channels rather than social media.

****Enforcement:****

1. Violations of this policy may result in disciplinary action, up to and including termination of employment.
2. The Town of Lynnville reserves the right to monitor social media activity related to town business and investigate any reports of policy violations.

****Policy Review:****

This policy will be reviewed annually and updated as necessary to reflect changes in technology, legal requirements, and best practices.

****Acknowledgment:****

Employees must sign an acknowledgment form indicating they have read, understood, and agreed to comply with this policy. Failure to sign the acknowledgment does not exempt employees from adhering to the policy.

Approved by:

[Name/Title]

Date: [Approval Date]

Effective Date: [Effective Date]

Purchase Orders

PO Number	Date	Dept	Issued By	Issued To	Type (Op, Office, Project, Misc)	Store	Amount	Receipt	Notes	Turned In
?-2592	1/2/2025		Megan	Scott	Clamps for flagpole	4Js	6.76	Y	Inv 62742	
WW-2593	1/2/2025		Megan	Brian	Couplings for Blower at plant	Ryan's Hardware	38.85	Y	*Reimbursement	
?-2594	1/2/2025		Megan		Employee Hoodies	Tammy Boruff				
PD-2595	1/2/2025	Police	Megan	Mike Mitchell	IACP conference	IACP	350	Y	Inv 103176	Y
?-2596	1/3/2025		Megan		Jacob Green	Mceen LLC	6820	Y	Inv 1012	Y
?-2597	1/3/2025		Megan	Brian	Spring Conference	Alliance of IN Rural Water	265	Y	On CC	Y
P-2598	1/3/2025	Park	Megan	Katie	Rec Bldg Repair	Lowes, M&M Hardware	142.3	Y	Reimbursement	Y
P-2599	1/3/2025	Park	Megan	Katie	Tail light for Ranger	Autozone	8.07	Y	Inv 2604228657	Y
?-2600	1/3/2025		Megan			Commonweath	1668.15	Y	Inv 61865	Y
F-2601	1/3/2025	Fire	Megan		Transfer	Home Depot	239.43	Y	FD funds transfer request	Y
?-2602	1/8/2025		Megan	Travis	Ice melt	Home Depot	304.98	Y		Y
?-2603	1/8/2025		Megan	David	Town Hall furniture	Corporate Design	12,339.31		Quote 43166	
F-2604	1/8/2025	Fire	Megan		Year 5/5	IamResponding	305	Y	Inv 7702	Y
PD-2605	1/8/2025	PD	Megan		Membership Renewal	IACP	235	Y	Inv 103001	Y
F-2606	1/8/2025	Fire	Megan		Transfer	Walmart, DG, etc	756.56	Y		Y
F-2607	1/8/2025	Fire	Megan		Rechargeable batteries	Nichols Fire & Fleet	113.2	Y	Inv 51929	Y
CC-2608A	1/9/2025	Comm Center	Megan	David	Comm Center Bathroom	TK Taylor Home Repair	4040	Y	To begin job	Y
CC-2608B	1/9/2025	Comm Center	Megan	David	Comm Center Bathroom	TK Taylor Home Repair	4040			
P-2609	1/9/2025	Park	Megan		Rec Bldg Repair	4Js	61.26	Y	At job finish	Y
P-2610	1/9/2025	Park	Megan	David	Kubota Repair	Hopt	8598.53	Y	Quote 02-52562	Y
F-2611	1/13/2025	Fire	Megan		Fire Dept	Sigets Uniforms	119.99	Y	Inv 592354-1	Y
?-2611	1/9/2025		Megan	Austin		Core and Main	44.77	Y	Inv W252868	Y
?-2612	1/13/2025		Megan		Base Fee, Flow Fee	IN Dept of Envir Management	1215.456	Y	Inv 383236, 376900	Y
?-2613	1/13/2025		Megan		4th Qtr Ticket Fees	IN 811	179.55	Y	Inv-11163	Y
?-2614	1/14/2025		Megan	Brian	AIRW-Spring Conference	French Lick Resort	280	Y		Y
W/WW-2615	1/14/2025		Megan			SBOA	27,297.60	Y	Inv 3880, 3881	Y
?-2616	1/14/2025		Megan		Flags	American Legion	432	Y		Y

7-2617	1/16/2025	Megan	Scott	Repair F250	Amazon	109.09	Y		Y
7-2618	1/16/2025	Megan	David	Annex doors	PRPC	1457.57	Y	Estimate 1182	Y
W-2619	1/17/2025	Megan		Water Stock 2025 Q1	Core and Main				
7-2620	1/17/2025	Megan		Jump drives, Kleenex	Amazon	32.47	Y	Order-8222	Y
7-2621	1/17/2025	Megan	Brian	WWETT Show	WWETT, Hilton	170,908	Y		Y

Name	Full name	Today's date	Work completed:	Follow Up Required:	Request
Travis Porter	Travis Porter	45609	Hung bar to hang cleaning stuff	no	Hang utility rack in Town Hall bathroom.
Travis Porter	Travis Porter	45610	Yes- took lock of turned meters on Picture 1- 2647 Picture 2- 2643	No	Unlock meters for Howard Construction, 2647 and 2643 Lynn Ridge Circle
Travis Porter	Travis Porter	45611	Had to break ignition out as there is no keys for the truck. Once done with that hooked tractor and pulled out of barn and put by John's barn.	No	Move truck from Park Garage.
Travis Porter	Doug from Earthworks	45611	Turn Water On	No	Reconnect at 433 W SR 68 for Kenneth Powers.
Travis Porter	Travis Porter	45618	Trash, showed Dorris how to use the floor machine, talked to Dave and Dorris about the status of the floor. Grabbed the old toilet paper holders and soap dispensers to take to the annex.	Yes- need to replace batteries in thermostat will do today.	At Community Center - please take out trash and move old paper towel holders to storage. Also confirm if floor scrubber is operational.
Scott Whitfield	Whitfield	45630	Located water pit showed the home owner its location and uncovered it	Job complete	Locate and mark water pit so customer can install water shut off.
Scott Whitfield	Whitfield	45630	Checked antenna all appeared to be in working order	No	Check antenna at elementary school.
Scott Whitfield	Whitfield	45630	3 inch riser and new cap installed	Additional dirt may be required	Raise lid at 225 Oak St
Travis Porter	Travis Porter	45631	Hardware store to get 2 keys made	No	Get copies of TH key made.

Scott Whitfield	Whitfield	45635	Checked connections everything looks good need to concern the numbers 1576496930	Check id in the system	Check antenna at 2643 Lynn Ridge
Travis Porter	Travis Porter	45635	Removed lock turned water on	No	Remove lock on meter at 221 3rd St for Modlin - Balance was paid online today.
Travis Porter	Travis Porter	45635	New stop sign pole and sign	No	Fix stop/street signs at Church and Third
Travis Porter	Travis Porter Michael Garrison	45636	Yes moved totes and christmas stuff back to annex	no	Move Christmas decorations from TH to annex
Travis Porter	Travis Porter	45638	515 N Main St off 10:25 533 N Main St. off 10:29 428 E First St. Off 10:35	Yes- when bills are pd	nonpayment at: 318 E State Route 68 - Angel Thacker 515 N Main St - Jessica Boger
Travis Porter	Travis Porter	45638	Water turned on 11:38	No	Reconnect service at 515 N Main St - Jessica Boger, payment made in Town Hall.
Travis Porter	Travis Porter	45638	Turn water on	No	Reconnect service at 428 E 1st St - Brian Bender, payment made online.
Travis Porter	Travis Porter	45638	Turn water on	No	Reconnect service at 318 E State Route 68 - Angel Thacker, payment made online.
Travis Porter	Travis Porter	45639	Broke boxes down took to wastewater plant to dispose.	No	Move boxes at community center.

Travis Porter	Travis Porter	45639	Moved grill tanks canopy. Also moved extra chairs to trail head building	No	Per Rachel: Move new blackstone griddle and Grinch Chair to Community center. Blackstone will need tanks. Move 2 easy up canopies from park to community center.
Travis Porter	Scott, Michael, Travis	45643	Moved caps from town hall and annex	No	Take plastic caps from Annex to dumpster.
Travis Porter	Brian Cook	45643	Took chairs to Johnny Ray's for auction	Yes	Move chairs from Town Hall to Annex.
Travis Porter	Travis Porter	45642	2 Trips to menards	No	Order pickup at Menards for ice melt and RV antifreeze. Sending to both Travis and Scott, please coordinate who will do the pickup, any time this week! Thank you
Scott Whitfield	Scott Whitfield	45653	Ditches cleaned out the best we can the first problem is the collapsed pipe under the driveway the second problem is ours on the corner lot that is not rented has a pipe under part of it and is stopped up and we need to be jettied to fix the problem	Yes	Culvert near 115 Possum Ln - Culvert is possibly collapsed. Need documentation of what is causing it to back up - leasee's or town's responsibility? Is it collapsed? Etc.
Scott Whitfield	Scott Whitfield	45653	Moved to park office	No	Move filing cabinet
Scott Whitfield	Scott Whitfield	45659	4 cable clamps installed	Yes cable needs to be replaced	Temporary fix on flagpole for American flag to be hung back up.
Travis Porter	Travis Porter	45664	Shoveled entrance and moved pile snow in parking lot	No	Clear sidewalks at Town Hall for meeting tonight.

Travis Porter	Travis Porter	45671	416 first street turn water off 122 wait customer called and waiting to hear back town hall	Yes	Disconnect water for nonpayment at: 416 E 1st St - Michael King 122 W SR 68 - Theodore Browning
Travis Porter	Travis Porter	45671	Took picture final read	No	Final Reading for 2643 Lynn Ridge
Brian Cook	brian cook Scott Whitfield	45672 45673	turn water back on Completed	no No	Reconnect service at 416 E 1st St - Michael King. Paid in full.
Travis Porter	Travis Porter	11/13/2024	Yes- checked for chlorine, no chlorine present. Looks as if could be run off water from rain over the weekend.	Yes- will check in couple days see if there us still seepage.	Check for slow leak at 2nd and Main per David
Travis Porter	Travis Porter	11/13/2024	Yes 10:35 Reading: 96470.2 Lock put on	No	Disconnect at 433 W SR 68 for Kenneth Powers.
			Completed by Wyatt		Put heaters in front of Town Hall away.
			Completed by Scott		Customer reported a culvert needs cleared at 1st and Church St.
			Completed by Scott Completed by Travis		Clean culvert at 206 Deer Lane that goes under road, per Lauri.
					Clear parking lot of Rec Bldg
					Work on filling at Town Annex. See Lauri for details.
			Completed by Scott		Inspect tree removal at 210 Violet Ln (Jay Almon).

Notification of ACH Payment

To:
Of:
TOWN OF LYNNVILLE

From the Office

ELISE NIESHALLA

State

200 W.

ROOM 240

INDIANAPOLIS,

RECEIVED

207 MAIN ST
Comptroller
PO BOX 99
WASHINGTON ST
LYNNVILLE, IN 47619
STATEHOUSE

IN 46204

Lynnville Clerk Treasurer

Vendor ID	Bank ID #	Bank Account #	Payment Date	Handling Cd
0000072529	XXXXX8161	XXX0688	01/21/2025	UT

Payment Reference	Payment Amount	Unit	Description
012053480	311926.80	00800	Transportation

Invoice ID	PO ID	Invoice Dt	Gross
Discount	Late Charge	Net	

INDOT OCT24 1800176 UT 1	01/08/2025	311926.80
0.00	0.00	311926.80

*Payment Message: Inv#: INDOT OCT24 1800176 UT 1 PO 0020119779 DES 1800176 CPM

APPROVED
JAN 21 2025

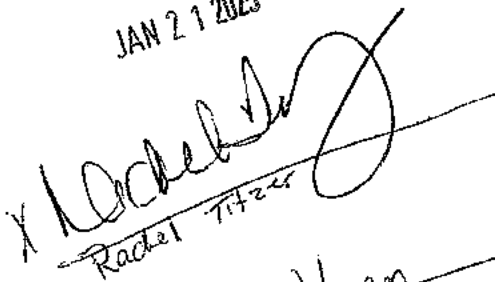
X 
Rachel Titzer

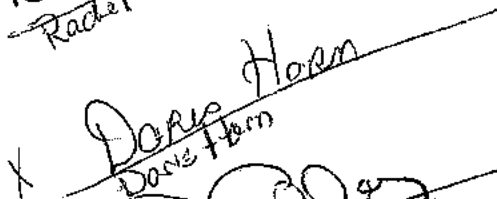
X 
Dawn Horn

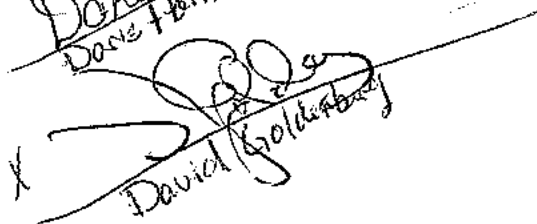
X 
David Goldsberry



Town of Lynnville

207 Main St, P.O. Box 99

Lynnville, IN 47619

812-922-5111

townoflynnville.com

November 03, 2024

Invoice #1

Bill to		Ship to	
Customer	INDOT 3650 South U.S. Highway 41 Vincennes, IN 47591 Attn: David Farmer	Recipient Address	Town of Lynnville P.O. Box 99 207 Main St. Lynnville, IN 47619
Customer ID#	INDOT DES #1800176	Phone	812-922-5111
Payment Terms	Upon receipt		

Qty	Item #	Description	Unit Price	Discount	Line Total
1	22265	2023 Expenditures	\$62,205.14		\$62,205.14
1	22215	Bidding and negotiating	\$1,482.00		\$1,482.00
1	22393	Permit Assistance	\$8,871.11		\$8,871.11
1	22393	Bidding and negotiating	\$2,508.00		\$2,508.00
1	22535	Permit Assist. and Easement Prep	\$518.67		\$518.67
1	22641	Construction	\$5,206.45		\$5,206.45
1	22685	Supplies	\$3,200.00		\$3,200.00
1	22761	Construction	\$2,967.64		\$2,967.64
1	22864	Contractor Application #1	\$120,702.25		\$120,702.25
1	22877	Construction and Res Project Rep	\$3,031.46		\$3,031.46
1	22932	Contractor Application #2	\$89,300.00		\$89,300.00
1	22977	Supplies	\$305.40		\$305.40
1	22977	Supplies	\$308.26		\$308.26
1	22977	Supplies	\$1,403.17		\$1,403.17
1	22975	Setters	\$2,160.00		\$2,160.00
1	23031	Construction	\$36.93		\$36.93
1	23031	Res. Project Rep	\$1,746.32		\$1,746.32
1	23011	Supplies	\$3,004.00		\$3,004.00
1	23073	Hydo Excavating	\$540.00		\$540.00
1	23073	Hydro Excavating	\$2,430.00		\$2,430.00

Total Discount	\$0.00
Subtotal	\$311,926.80
Sales Tax	\$0.00
Total	\$311,926.80

Lauri Stockus
 Clerk Treasurer
clerk-treasurer@townoflynnville.com
 812-922-5111
 townoflynnville.com

Mailed 11/3/2024

Purchase Order



Dispatch via Print

Transportation
Dept Of Transportation
Finance Operations Support
100 N SENATE AVE RM N758-ACT
INDIANAPOLIS IN 46204
United States

Supplier: 0000072529
TOWN OF LYNNVILLE
207 MAIN ST
PO BOX 99
LYNNVILLE IN 47619

Purchase Order 00800-0020119779	Date 01/04/2024	Revision 1	Page 1
Payment Terms 35 Arrears	Freight Terms FOB DESTINATION	Ship Via VENDOR RESPONSIBL	
Buyer Cheri Marsischky - 00800	Phone/Email	Currency USD	

Ship To: 800IDOT227
Dept of Transportation
Utility & Railroad
100 N SENATE AVE RM N758-U&R
INDIANAPOLIS IN 46204
United States

Attention: Cheri Marsischky - 00800

Bill To: Dept Of Transportation
Vincennes District
3650 S US HWY 41
VINCENNES IN 47591
United States

Tax Exempt? Y **Tax Exempt ID:** 0004897013

Replenishment Option: Standard

Line-Sch	Item/Description	Mfg ID	Quantity	UOM	PO Price	Extended Amt	Due Date
1- 1	DES 1800176 Project # 800180017600ST6		1.00	EA	482,787.15	482,787.15	01/27/2024
Schedule Total						<u>482,787.15</u>	

CapWise Fund Request Attachment

Authorized Signature

Waterline Relocation Project

Date	APV	\$	Vendor	Description
01/31/2024	22265	\$62,205.14	Commonwealth	2023 Expenditures
04/16/2024	22215	\$1,482.00	Commonwealth	Bidding and negotiating
05/20/2024	22393	\$8,871.11	Commonwealth	Permit Assistance
05/20/2024	22393	\$2,508.00	Commonwealth	Bidding and negotiating
06/17/2024	22535	\$518.67	Commonwealth	Permit Assistance and Easement Prep
07/16/2024	22641	\$5,206.45	Commonwealth	Construction
07/29/2024	22685	\$3,200.00	Wilcox	Supplies
08/20/2024	22761	\$2,967.64	Commonwealth	Construction
09/17/2024	22864	\$120,702.25	Guardian	Contractor Application #1
09/23/2024	22877	\$3,031.46	Commonwealth	Construction and Resident Project Rep
10/03/2024	22932	\$89,300.00	Guardian	Contractor Application #2
10/14/2024	22977	\$305.40	Core & Main	Supplies
10/14/2024	22977	\$308.26	Core & Main	Supplies
10/14/2024	22977	\$1,403.17	Core & Main	Supplies
10/14/2024	22975	\$2,160.00	Wilcox	Setters
10/18/2024	23031	\$36.93	Commonwealth	Construction
10/18/2024	23031	\$1,746.32	Commonwealth	Resident Project Rep
10/18/2024	23011	\$3,004.00	Core & Main	Supplies
10/24/2024	23073	\$540.00	3D Leasing	Hydro Excavating
10/24/2024	23073	\$2,430.00	3D Leasing	Hydro Excavating
Total		\$311,926.80		